

Operator's Manual

CWT[™] *WOC-2*

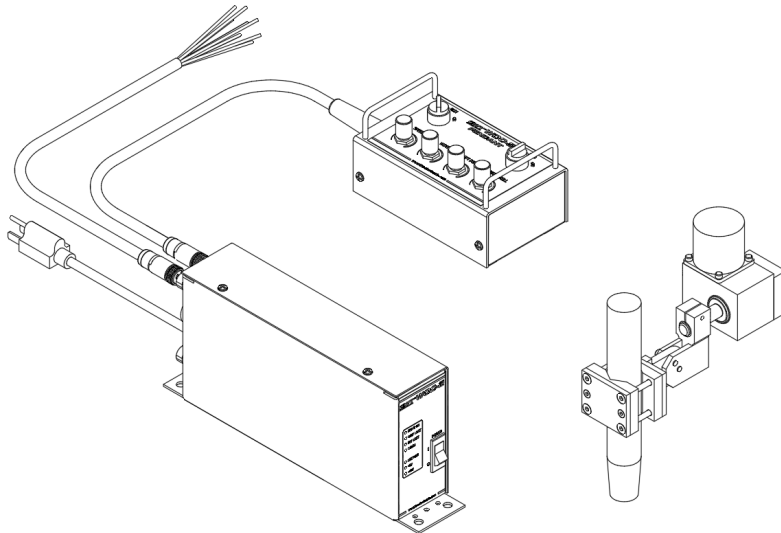

For use with machines having Numbers:
E0A5023, E0A5024



Register your machine:
www.lincolnelectric.com/register

Authorized Service and Distributor Locator:
www.lincolnelectric.com/locator

Save for future reference

Date Purchased

Code: (ex: 10859)

Serial: (ex: U1060512345)

THANK YOU FOR SELECTING A QUALITY PRODUCT BY LINCOLN ELECTRIC.

PLEASE EXAMINE CARTON AND EQUIPMENT FOR DAMAGE IMMEDIATELY

When this equipment is shipped, title passes to the purchaser upon receipt by the carrier. Consequently, claims for material damaged in shipment must be made by the purchaser against the transportation company at the time the shipment is received.

SAFETY DEPENDS ON YOU

Lincoln arc welding and cutting equipment is designed and built with safety in mind. However, your overall safety can be increased by proper installation ... and thoughtful operation on your part. **DO NOT INSTALL, OPERATE OR REPAIR THIS EQUIPMENT WITHOUT READING THIS MANUAL AND THE SAFETY PRECAUTIONS CONTAINED THROUGHOUT.** And, most importantly, think before you act and be careful.

WARNING

This statement appears where the information must be followed exactly to avoid serious personal injury or loss of life.

CAUTION

This statement appears where the information must be followed to avoid minor personal injury or damage to this equipment.



KEEP YOUR HEAD OUT OF THE FUMES.

DON'T get too close to the arc. Use corrective lenses if necessary to stay a reasonable distance away from the arc.

READ and obey the Safety Data Sheet (SDS) and the warning label that appears on all containers of welding materials.

USE ENOUGH VENTILATION or exhaust at the arc, or both, to keep the fumes and gases from your breathing zone and the general area.

IN A LARGE ROOM OR OUTDOORS, natural ventilation may be adequate if you keep your head out of the fumes (See below).

USE NATURAL DRAFTS or fans to keep the fumes away from your face.

If you develop unusual symptoms, see your supervisor. Perhaps the welding atmosphere and ventilation system should be checked.

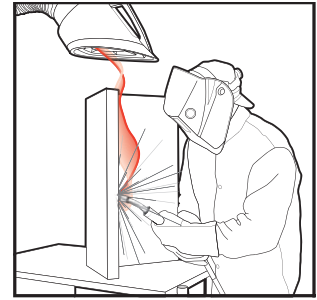

WEAR CORRECT EYE, EAR & BODY PROTECTION

PROTECT your eyes and face with welding helmet properly fitted and with proper grade of filter plate (See ANSI Z49.1).

PROTECT your body from welding spatter and arc flash with protective clothing including woolen clothing, flame-proof apron and gloves, leather leggings, and high boots.

PROTECT others from splatter, flash, and glare with protective screens or barriers.

IN SOME AREAS, protection from noise may be appropriate.

BE SURE protective equipment is in good condition.

Also, wear safety glasses in work area **AT ALL TIMES.**



SPECIAL SITUATIONS

DO NOT WELD OR CUT containers or materials which previously had been in contact with hazardous substances unless they are properly cleaned. This is extremely dangerous.

DO NOT WELD OR CUT painted or plated parts unless special precautions with ventilation have been taken. They can release highly toxic fumes or gases.

Additional precautionary measures

PROTECT compressed gas cylinders from excessive heat, mechanical shocks, and arcs; fasten cylinders so they cannot fall.

BE SURE cylinders are never grounded or part of an electrical circuit.

REMOVE all potential fire hazards from welding area.

ALWAYS HAVE FIRE FIGHTING EQUIPMENT READY FOR IMMEDIATE USE AND KNOW HOW TO USE IT.



SECTION A: WARNINGS



CALIFORNIA PROPOSITION 65 WARNINGS



WARNING: Breathing diesel engine exhaust exposes you to chemicals known to the State of California to cause cancer and birth defects, or other reproductive harm.

- Always start and operate the engine in a well-ventilated area.
- If in an exposed area, vent the exhaust to the outside.
- Do not modify or tamper with the exhaust system.
- Do not idle the engine except as necessary.

For more information go to www.P65warnings.ca.gov/diesel

WARNING: This product, when used for welding or cutting, produces fumes or gases which contain chemicals known to the State of California to cause birth defects and, in some cases, cancer. (California Health & Safety Code § 25249.5 *et seq.*)



WARNING: Cancer and Reproductive Harm
www.P65warnings.ca.gov

ARC WELDING CAN BE HAZARDOUS. PROTECT YOURSELF AND OTHERS FROM POSSIBLE SERIOUS INJURY OR DEATH. KEEP CHILDREN AWAY. PACEMAKER WEARERS SHOULD CONSULT WITH THEIR DOCTOR BEFORE OPERATING.

Read and understand the following safety highlights. For additional safety information, it is strongly recommended that you purchase a copy of "Safety in Welding & Cutting - ANSI Standard Z49.1" from the American Welding Society, P.O. Box 351040, Miami, Florida 33135 or CSA Standard W117.2-1974. A Free copy of "Arc Welding Safety" booklet E205 is available from the Lincoln Electric Company, 22801 St. Clair Avenue, Cleveland, Ohio 44117-1199.

BE SURE THAT ALL INSTALLATION, OPERATION, MAINTENANCE AND REPAIR PROCEDURES ARE PERFORMED ONLY BY QUALIFIED INDIVIDUALS.



FOR ENGINE POWERED EQUIPMENT.

- 1.a. Turn the engine off before troubleshooting and maintenance work unless the maintenance work requires it to be running.
- 1.b. Operate engines in open, well-ventilated areas or vent the engine exhaust fumes outdoors.
- 1.c. Do not add the fuel near an open flame welding arc or when the engine is running. Stop the engine and allow it to cool before refueling to prevent spilled fuel from vaporizing on contact



with hot engine parts and igniting. Do not spill fuel when filling tank. If fuel is spilled, wipe it up and do not start engine until fumes have been eliminated.

- 1.d. Keep all equipment safety guards, covers and devices in position and in good repair. Keep hands, hair, clothing and tools away from V-belts, gears, fans and all other moving parts when starting, operating or repairing equipment.
- 1.e. In some cases it may be necessary to remove safety guards to perform required maintenance. Remove guards only when necessary and replace them when the maintenance requiring their removal is complete. Always use the greatest care when working near moving parts.
- 1.f. Do not put your hands near the engine fan. Do not attempt to override the governor or idler by pushing on the throttle control rods while the engine is running.
- 1.g. To prevent accidentally starting gasoline engines while turning the engine or welding generator during maintenance work, disconnect the spark plug wires, distributor cap or magneto wire as appropriate.
- 1.h. To avoid scalding, do not remove the radiator pressure cap when the engine is hot.



ELECTRIC AND MAGNETIC FIELDS MAY BE DANGEROUS



- 2.a. Electric current flowing through any conductor causes localized Electric and Magnetic Fields (EMF). Welding current creates EMF fields around welding cables and welding machines
- 2.b. EMF fields may interfere with some pacemakers, and welders having a pacemaker should consult their physician before welding.
- 2.c. Exposure to EMF fields in welding may have other health effects which are now not known.
- 2.d. All welders should use the following procedures in order to minimize exposure to EMF fields from the welding circuit:
 - 2.d.1. Route the electrode and work cables together - Secure them with tape when possible.
 - 2.d.2. Never coil the electrode lead around your body.
 - 2.d.3. Do not place your body between the electrode and work cables. If the electrode cable is on your right side, the work cable should also be on your right side.
 - 2.d.4. Connect the work cable to the workpiece as close as possible to the area being welded.
 - 2.d.5. Do not work next to welding power source.



ELECTRIC SHOCK CAN KILL.



- 3.a. The electrode and work (or ground) circuits are electrically “hot” when the welder is on. Do not touch these “hot” parts with your bare skin or wet clothing. Wear dry, hole-free gloves to insulate hands.
- 3.b. Insulate yourself from work and ground using dry insulation. Make certain the insulation is large enough to cover your full area of physical contact with work and ground.

In addition to the normal safety precautions, if welding must be performed under electrically hazardous conditions (in damp locations or while wearing wet clothing; on metal structures such as floors, gratings or scaffolds; when in cramped positions such as sitting, kneeling or lying, if there is a high risk of unavoidable or accidental contact with the workpiece or ground) use the following equipment:

- Semiautomatic DC Constant Voltage (Wire) Welder.
 - DC Manual (Stick) Welder.
 - AC Welder with Reduced Voltage Control.
- 3.c. In semiautomatic or automatic wire welding, the electrode, electrode reel, welding head, nozzle or semiautomatic welding gun are also electrically “hot”.
 - 3.d. Always be sure the work cable makes a good electrical connection with the metal being welded. The connection should be as close as possible to the area being welded.
 - 3.e. Ground the work or metal to be welded to a good electrical (earth) ground.
 - 3.f. Maintain the electrode holder, work clamp, welding cable and welding machine in good, safe operating condition. Replace damaged insulation.
 - 3.g. Never dip the electrode in water for cooling.
 - 3.h. Never simultaneously touch electrically “hot” parts of electrode holders connected to two welders because voltage between the two can be the total of the open circuit voltage of both welders.
 - 3.i. When working above floor level, use a safety belt to protect yourself from a fall should you get a shock.
 - 3.j. Also see Items 6.c. and 8.



ARC RAYS CAN BURN.



- 4.a. Use a shield with the proper filter and cover plates to protect your eyes from sparks and the rays of the arc when welding or observing open arc welding. Headshield and filter lens should conform to ANSI Z87.1 standards.
- 4.b. Use suitable clothing made from durable flame-resistant material to protect your skin and that of your helpers from the arc rays.
- 4.c. Protect other nearby personnel with suitable, non-flammable screening and/or warn them not to watch the arc nor expose themselves to the arc rays or to hot spatter or metal.



FUMES AND GASES CAN BE DANGEROUS.



- 5.a. Welding may produce fumes and gases hazardous to health. Avoid breathing these fumes and gases. When welding, keep your head out of the fume. Use enough ventilation and/or exhaust at the arc to keep fumes and gases away from the breathing zone. **When welding hardfacing (see instructions on container or SDS) or on lead or cadmium plated steel and other metals or coatings which produce highly toxic fumes, keep exposure as low as possible and within applicable OSHA PEL and ACGIH TLV limits using local exhaust or mechanical ventilation unless exposure assessments indicate otherwise. In confined spaces or in some circumstances, outdoors, a respirator may also be required. Additional precautions are also required when welding on galvanized steel.**
- 5.b. The operation of welding fume control equipment is affected by various factors including proper use and positioning of the equipment, maintenance of the equipment and the specific welding procedure and application involved. Worker exposure level should be checked upon installation and periodically thereafter to be certain it is within applicable OSHA PEL and ACGIH TLV limits.
- 5.c. Do not weld in locations near chlorinated hydrocarbon vapors coming from degreasing, cleaning or spraying operations. The heat and rays of the arc can react with solvent vapors to form phosgene, a highly toxic gas, and other irritating products.
- 5.d. Shielding gases used for arc welding can displace air and cause injury or death. Always use enough ventilation, especially in confined areas, to insure breathing air is safe.
- 5.e. Read and understand the manufacturer’s instructions for this equipment and the consumables to be used, including the Safety Data Sheet (SDS) and follow your employer’s safety practices. SDS forms are available from your welding distributor or from the manufacturer.
- 5.f. Also see item 1.b.



WELDING AND CUTTING SPARKS CAN CAUSE FIRE OR EXPLOSION.

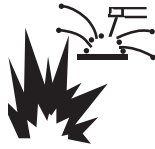

- 6.a. Remove fire hazards from the welding area. If this is not possible, cover them to prevent the welding sparks from starting a fire. Remember that welding sparks and hot materials from welding can easily go through small cracks and openings to adjacent areas. Avoid welding near hydraulic lines. Have a fire extinguisher readily available.
- 6.b. Where compressed gases are to be used at the job site, special precautions should be used to prevent hazardous situations. Refer to "Safety in Welding and Cutting" (ANSI Standard Z49.1) and the operating information for the equipment being used.
- 6.c. When not welding, make certain no part of the electrode circuit is touching the work or ground. Accidental contact can cause overheating and create a fire hazard.
- 6.d. Do not heat, cut or weld tanks, drums or containers until the proper steps have been taken to insure that such procedures will not cause flammable or toxic vapors from substances inside. They can cause an explosion even though they have been "cleaned". For information, purchase "Recommended Safe Practices for the Preparation for Welding and Cutting of Containers and Piping That Have Held Hazardous Substances", AWS F4.1 from the American Welding Society (see address above).
- 6.e. Vent hollow castings or containers before heating, cutting or welding. They may explode.
- 6.f. Sparks and spatter are thrown from the welding arc. Wear oil free protective garments such as leather gloves, heavy shirt, cuffless trousers, high shoes and a cap over your hair. Wear ear plugs when welding out of position or in confined places. Always wear safety glasses with side shields when in a welding area.
- 6.g. Connect the work cable to the work as close to the welding area as practical. Work cables connected to the building framework or other locations away from the welding area increase the possibility of the welding current passing through lifting chains, crane cables or other alternate circuits. This can create fire hazards or overheat lifting chains or cables until they fail.
- 6.h. Also see item 1.c.
- 6.i. Read and follow NFPA 51B "Standard for Fire Prevention During Welding, Cutting and Other Hot Work", available from NFPA, 1 Batterymarch Park, PO box 9101, Quincy, MA 022690-9101.
- 6.j. Do not use a welding power source for pipe thawing.



CYLINDER MAY EXPLODE IF DAMAGED.



- 7.a. Use only compressed gas cylinders containing the correct shielding gas for the process used and properly operating regulators designed for the gas and pressure used. All hoses, fittings, etc. should be suitable for the application and maintained in good condition.
- 7.b. Always keep cylinders in an upright position securely chained to an undercarriage or fixed support.
- 7.c. Cylinders should be located:
 - Away from areas where they may be struck or subjected to physical damage.
 - A safe distance from arc welding or cutting operations and any other source of heat, sparks, or flame.
- 7.d. Never allow the electrode, electrode holder or any other electrically "hot" parts to touch a cylinder.
- 7.e. Keep your head and face away from the cylinder valve outlet when opening the cylinder valve.
- 7.f. Valve protection caps should always be in place and hand tight except when the cylinder is in use or connected for use.
- 7.g. Read and follow the instructions on compressed gas cylinders, associated equipment, and CGA publication P-1, "Precautions for Safe Handling of Compressed Gases in Cylinders," available from the Compressed Gas Association, 14501 George Carter Way Chantilly, VA 20151.



FOR ELECTRICALLY POWERED EQUIPMENT.



- 8.a. Turn off input power using the disconnect switch at the fuse box before working on the equipment.
- 8.b. Install equipment in accordance with the U.S. National Electrical Code, all local codes and the manufacturer's recommendations.
- 8.c. Ground the equipment in accordance with the U.S. National Electrical Code and the manufacturer's recommendations.

Refer to
<http://www.lincolnelectric.com/safety>
for additional safety information.

ELECTROMAGNETIC COMPATIBILITY (EMC)

CONFORMANCE

Products displaying the CE mark are in conformity with European Community Council Directive. It was manufactured in conformity with a national standard that implements a harmonized standard: EN 60974-10 Electromagnetic Compatibility (EMC) Product Standard for Arc Welding Equipment. It is for use with other Lincoln Electric equipment. It is designed for industrial and professional use.

INTRODUCTION

All electrical equipment generates small amounts of electromagnetic emission. Electrical emission may be transmitted through power lines or radiated through space, similar to a radio transmitter. When emissions are received by other equipment, electrical interference may result. Electrical emissions may affect many kinds of electrical equipment; other nearby welding equipment, radio and TV reception, numerical controlled machines, telephone systems, computers, etc.

WARNING: This Class A equipment is not intended for use in residential locations where the electrical power is provided by the public low-voltage supply system. There may be potential difficulties in ensuring electro-magnetic compatibility in those locations, due to conducted as well as radiated disturbances.

INSTALLATION AND USE

The user is responsible for installing and using the welding equipment according to the manufacturer's instructions.

If electromagnetic disturbances are detected then it shall be the responsibility of the user of the welding equipment to resolve the situation with the technical assistance of the manufacturer. In some cases this remedial action may be as simple as earthing (grounding) the welding circuit, see Note. In other cases it could involve constructing an electromagnetic screen enclosing the power source and the work complete with associated input filters. In all cases electromagnetic disturbances must be reduced to the point where they are no longer troublesome.

NOTE: The welding circuit may or may not be earthed for safety reasons. Follow your local and national standards for installation and use. Changing the earthing arrangements should only be authorized by a person who is competent to assess whether the changes will increase the risk of injury, e.g., by allowing parallel welding current return paths which may damage the earth circuits of other equipment.

ASSESSMENT OF AREA

Before installing welding equipment the user shall make an assessment of potential electromagnetic problems in the surrounding area. The following shall be taken into account:

- a) other supply cables, control cables, signaling and telephone cables; above, below and adjacent to the welding equipment;
- b) radio and television transmitters and receivers;
- c) computer and other control equipment;
- d) safety critical equipment, e.g., guarding of industrial equipment;
- e) the health of the people around, e.g., the use of pacemakers and hearing aids;
- f) equipment used for calibration or measurement;
- g) the immunity of other equipment in the environment. The user shall ensure that other equipment being used in the

environment is compatible. This may require additional protection measures;

- h) the time of day that welding or other activities are to be carried out.

The size of the surrounding area to be considered will depend on the structure of the building and other activities that are taking place. The surrounding area may extend beyond the boundaries of the premises.

METHODS OF REDUCING EMISSIONS

Public Supply System

Welding equipment should be connected to the public supply system according to the manufacturer's recommendations. If interference occurs, it may be necessary to take additional precautions such as filtering of the system. Consideration should be given to shielding the supply cable of permanently installed welding equipment, in metallic conduit or equivalent. Shielding should be electrically continuous throughout its length. The shielding should be connected to the welding power source so that good electrical contact is maintained between the conduit and the welding power source enclosure.

Maintenance of the Welding Equipment

The welding equipment should be routinely maintained according to the manufacturer's recommendations. All access and service doors and covers should be closed and properly fastened when the welding equipment is in operation. The welding equipment should not be modified in any way except for those changes and adjustments covered in the manufacturer's instructions. In particular, the spark gaps of arc striking and stabilizing devices should be adjusted and maintained according to the manufacturer's recommendations.

Welding Cables

The welding cables should be kept as short as possible and should be positioned close together, running at or close to the floor level.

Equipotential Bonding

Bonding of all metallic components in the welding installation and adjacent to it should be considered. However, metallic components bonded to the work piece will increase the risk that the operator could receive a shock by touching these metallic components and the electrode at the same time. The operator should be insulated from all such bonded metallic components.

Earthing of the Workpiece

Where the workpiece is not bonded to earth for electrical safety, nor connected to earth because of its size and position, e.g., ship's hull or building steelwork, a connection bonding the workpiece to earth may reduce emissions in some, but not all instances. Care should be taken to prevent the earthing of the workpiece increasing the risk of injury to users, or damage to other electrical equipment. Where necessary, the connection of the workpiece to earth should be made by a direct connection to the workpiece, but in some countries where direct connection is not permitted, the bonding should be achieved by suitable capacitance, selected according to national regulations.

Screening and Shielding

Selective screening and shielding of other cables and equipment in the surrounding area may alleviate problems of interference. Screening of the entire welding installation may be considered for special applications.¹

¹ Portions of the preceding text are contained in EN 60974-10 "Electromagnetic Compatibility (EMC) product standard for arc welding equipment."

Table of Contents

1.0	GENERAL DESCRIPTION	1
1.0	FUNCTIONAL DESCRIPTION.....	1
1.1	CONTROL SPECIFICATIONS.....	2
2.0	INSTALLATION AND OPERATION	4
2.1	LOCATION.....	4
2.2	CABLES	7
2.3	OPERATION.....	7
2.4	USER I/O CONTROLS	7
2.5	USER CONTROLS AND STATUS LED'S	9
2.7	STEPPER MOTOR INTERFACE	11
3.0	WOC-2 OFF-LINE SERIAL TERMINAL PROTOCOL	12
3.1	COMMUNICATION SELECTION	12
3.2	RS-485 COMMUNICATIONS ASCII PROTOCOL	13
3.3	PORT PROTOCOL.....	13
3.4	TERMINAL COMMANDS.....	14
4.0	WOC-2 MODBUS MEMORY MAP.....	16
4.1	GENERAL DESCRIPTION.....	16
4.2	SUPPORTED MODBUS COMMANDS.....	16
4.3	MEMORY MAP FOR COILS (MODBUS COMMAND 01,05,15).....	16
4.4	COIL DEFINITIONS AND OPERATION.....	17
4.5	MEMORY MAP FOR HOLDING REGISTER (MODBUS COMMAND 03, 06, 16)	17
4.6	COIL DEFINITIONS AND OPERATION.....	18
4.7	MEMORY MAP FOR SLAVE ID (MODBUS COMMAND 17).....	18
5.0	WOC-2 MODBUS CONTROL OPERATION	19
5.1	GENERAL DESCRIPTION.....	19
5.2	INITIALIZATION OF WOC-2 FROM POWER UP	19
5.3	MOVE SLIDE TO POSITION AFTER INITIALIZATION	19
5.4	USE WOC-2 OSCILLATOR FUNCTION AFTER INITIALIZATION	20
6.0	COMMUNICATION DIAGRAMS	21
APPENDIX A	WOC-2 SYSTEM DRAWINGS.....	24
A.1	WOC-2 SYSTEM 110VAC P/N: E0A5023	24
A.2	WOC-2 SYSTEM 220VAC P/N: E0A5024	25
A.3	WOC-2 ENCLOSURE ASSEMBLY 110VAC P/N: E3A5070-OSC	26
A.4	WOC-2 ENCLOSURE ASSEMBLY 220VAC P/N: E3A5071-OSC	28
A.5	WOC-2 OPERATOR PENDANT P/N: E3A5069.....	30
A.6	REMOTE I/O CABLE P/N: S3W5227	32
A.7	PENDULUM OSCILLATOR ASSEMBLY P/N: E2A5179.....	33
A.8	OSCILLATOR MOTOR CABLE P/N: E3W5055-8.....	35
APPENDIX B	ACCESSORIES FOR PENDULUM OSCILLATOR.....	36
B.1	OSCILLATOR AND TORCH MOUNTING ACCESSORIES.....	36
B.2	PENDULUM OSCILLATOR ADJUSTABLE MOUNT ASSEMBLY P/N: E2A5187	37
B.3	PENDULUM OSCILLATOR ADJUSTABLE ARM ASSEMBLY P/N: E2A5186.....	38
B.4	ADJUSTABLE TORCH MOUNT ASSEMBLY P/N: E2A5185	39
B.5	TYPICAL INSTALLATION LAYOUTS FOR ACCESSORY PARTS.....	40

B.6	OPTIONAL MOUNTINGS FOR ADJUSTABLE MOUNT ASSEMBLY	41
B.7	BASE MOUNTING PLATE OPTIONAL MOUNTING CONFIGURATIONS	42
B.8	IN-LINE SHAFT WITH TOP MOUNTED BASE MOUNTING PLATE	43
B.9	IN-LINE SHAFT WITH SIDE MOUNTED BASE MOUNTING PLATE	44
B.10	IN-LINE SHAFT WITH BACK MOUNTED BASE MOUNTING PLATE.....	45
B.11	RIGHT ANGLED SHAFT WITH TOP MOUNTED BASE MOUNTING PLATE.....	46
B.12	RIGHT ANGLED SHAFT WITH SIDE MOUNTED BASE MOUNTING PLATE.....	47
B.13	RIGHT ANGLED SHAFT WITH REAR MOUNTED BASE MOUNTING PLATE	48

1.0 GENERAL DESCRIPTION

1.0 FUNCTIONAL DESCRIPTION

The Lincoln Electric Company Weld Oscillator Control (WOC-2) is a compact, lightweight, weld torch manipulation control system comprised of the micro-controller based Weld Oscillator Control (WOC-2), a stepper motor driven Pendulum Oscillator Assembly (POA) and a remote operator pendant. This system is capable of providing independent control of all torch movements in the horizontal plan.

System Part Number

PART NUMBERS	DESCRIPTIONS
E0A5023	WOC-2 Pendulum 110VAC System
E0A5024	WOC-2 Pendulum 220VAC System
E2A5185	Adjustable Torch Mount
E2A5186	Adjustable Mount
E2A5187	Adjustable Arm

The Weld Oscillator Control (WOC 2) provides the necessary command signals to the stepper motor powered drive to permit the selection of the following functions from the remote operator pendant.

CONTROL	FUNCTION
RUN	Enables oscillation.
JOG	Jog the center position in a CW or CCW direction.
SPEED	Control the speed of the oscillation.
LEFT DWELL	Control the dwell time on the left side of the oscillation pattern.
RIGHT DWELL	Control the dwell time on the right side of the oscillation pattern.
WIDTH	Control the width or amplitude of the weave pattern.

The Pendulum Oscillator Assembly (POA) is a stepper motor driven mechanical assembly that provides the oscillation motion for weld torch manipulation. The oscillator has a single 5/8-inch diameter output shaft for attachment of the user supplied welding torch. The oscillator module can be installed in any position and with a maximum rotational displacement of $\pm 15^\circ$.

WOC-2 SPECIFICATIONS

Drive Enclosure Dimensions	4.75"H X 2.25"W X 11.00"L (121mm X 57mm X 279mm)
Operator Pendant Dimensions	2.0"H x 3.5"W x 5.75"L (50mm x 89mm x 147 mm)
Weight	4 lbs (1.8kg) enclosure , 1.6 lbs Pendent
Power Requirements	115 vac 50/60 Hz @ 220 va
Dwell Time	0.02 to 2.0 seconds (left and right)
Velocity	100 – 6700 steps/sec
Peak Motor Current / Phase	2.0 – 6.0 amps
Remote I/O Output CR1, CR2	Isolated Solid State Relay (SSR) 28VDC max @ 100 ma
Remote I/O Inputs INP1, INP2	Isolated 28 VDC input @ 10 ma.

PENDULUM OSCILLATOR SPECIFICATIONS

Dimensions	3.50"H X 3.25"W X 5.75"L (90mm X 83mm X 146mm)
Weight	3 lbs (1.36kg)
Velocity	0.24° to 60° per second
Output Shaft Rotational Torque	820 ounce/inches
Output Shaft Holding Torque	1657 ounce/inches
Approximate Weight Limit	15 lbs at 3" from center of output shaft

The WOC-2 is a microprocessor based stepper motor controller which provides a 1/10 micro stepping output to operate most stepper drive motors requiring 1.0 – 6.5 amps/phase current. It includes an operator hand pendant that provides full control of the CWT torch positioning oscillator. The operator hand pendant operates as a Modbus Master and provides all of the required communications to operate the WOC-2 oscillation slide assembly. The smart hand pendant is used to control the slide position, speed, oscillation width and Left/Right dwell times. The control also provides a user I/O interface for remote control of the WOC. There are two isolated Solid State Relay (SSR) outputs CR1 (READY) and CR2 (OSC ON). There are two Isolated inputs INP1 (OSC ON) and INP2 (INITIALIZE) can be used to remote activate the Oscillator.

The WOC has an isolated RS-485 port that can be configured to allow off-line programming and control of the stepper motor driven pendulum oscillator. The RS-485 serial port supports the Modbus RTU protocol.

The WOC provides a constant current Sine/Cosine output to operate two-phase stepper motors. The output phase current can be user programmed from 1.0 – 6.5 amps. In the 1/10 step mode each step of the motor is subdivided into 10 micro steps. When using a 1.8 ° stepper motor the WOC will provide a 2000 step/rev output at a maximum speed of 240 rpm.

1.1 CONTROL SPECIFICATIONS

Control General Specification:

Control Dimension	4.75"H X 2.25"W X 11.00"L (121mm X 57mm X 279mm)
Mounting Dimension	1.25" wide x 10.25" long, four 0.25" diameter hole
Weight	4 lbs (1.8 kg)
Power Input	120 ±10% vac 50/60 hz @ 5.0 amps
Operating Temperature	-10°F (-23°C) to +140°F (+60°C)

Pendant General Specification:

Control Dimension	2.0"H x 3.5"W x 5.75"L (50mm x 89mm x 147 mm)
Mounting Dimension	Hand Held
Weight	1 lbs (1.18 kgms)
Power Input	24 VDC @ 0.2 amps
Operating Temperature	-10°F (-23°C) to +140°F (+60°C)

Motor Control Specification:

Motor Output Current	1.0 – 6.5 amps peak each phase
Motor Output Voltage	1.5 - 18.0 volts peak each phase
Current Profile	Sine/Cosine
Limit Switch Inputs	CW and CCW 5.0 vdc active low inputs with internal 4.7K ohm pull up resister
Brake Solenoid Output	24 vdc @ 0.5 amp for 0.5 seconds then 2.0 khz PWM modulated for 12 vdc hold-in voltage @ 0.5 amps
Step Resolution	10 micro steps/step
Velocity	10 - 8000 steps/sec. (Note: Max Speed Depends on Slide Assembly)
Acceleration	10 - 1000 steps/sec ²
Index Step Count	1 - 65535 steps
Index Scale Factor	1-255 steps/step scale factor
Communications	Isolated RS485 19,200 Baud Modbus RTU port

Remote Pendant Control Specification:

User Switch Control	Oscillator On/Off, Jog Slide Position CW/CCW
Oscillation/Slide Speed	Adjustable 0.1 to 100% Max Slide speed
Oscillation Width	Adjustable 0.1 to 98% of max slide length
Right Dwell time	Adjustable 0.05 to 2.50 seconds
Left Dwell Time	Adjustable 0.05 to 2.50 seconds

2.0 INSTALLATION AND OPERATION

2.1 LOCATION

The WOC-2 controller should be located near the stepper drive motor it is controlling. The maximum motor drive cable length is 75 ft. Mount the WOC-2 controller in a location that allows easy access to the front and rear panel. Figure 2-2 shows the WOC-2 System Diagram.

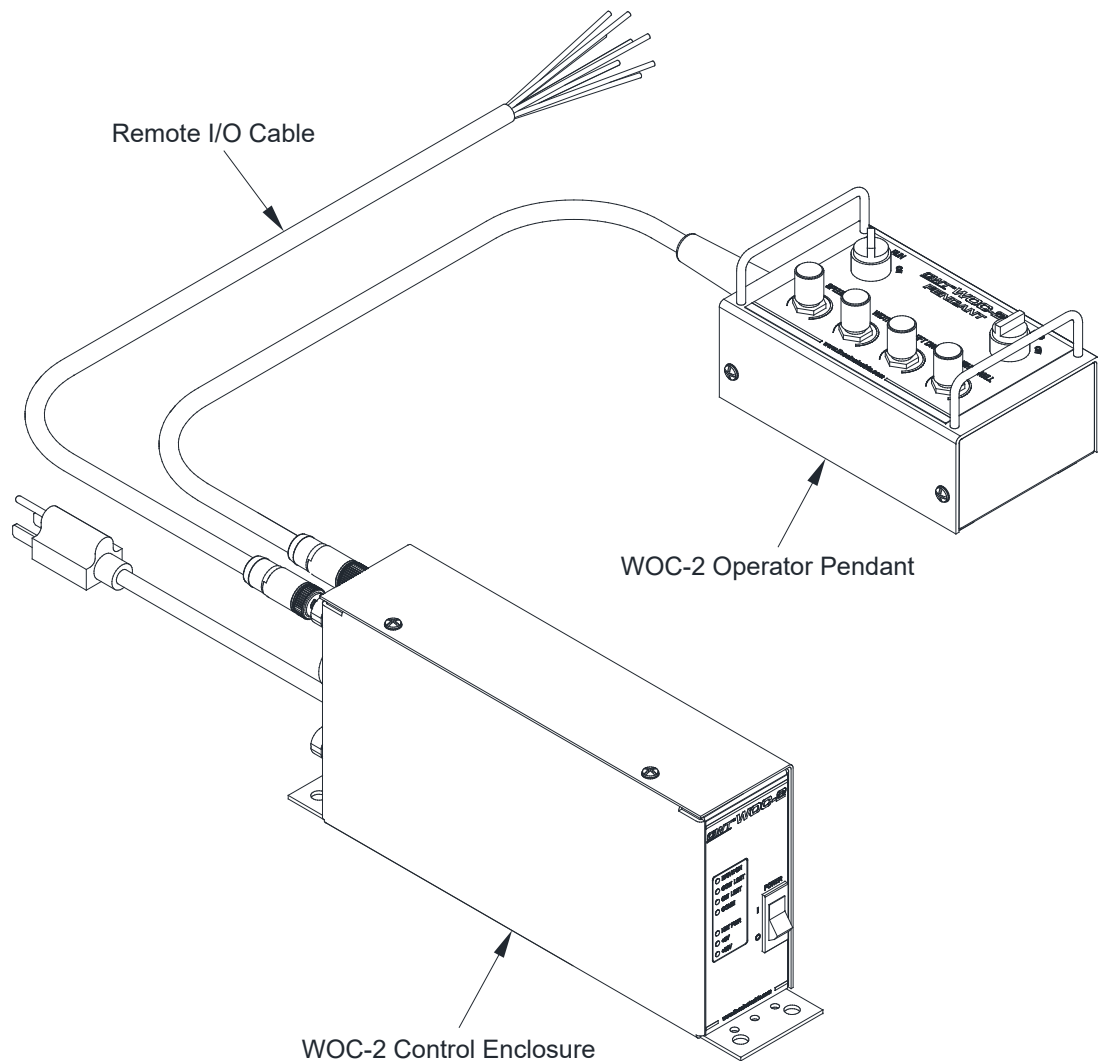

FIG 2-1: WOC-2 System Diagram

Figure 2-2 shows the mounting pattern for the WOC-2 Control Enclosure.

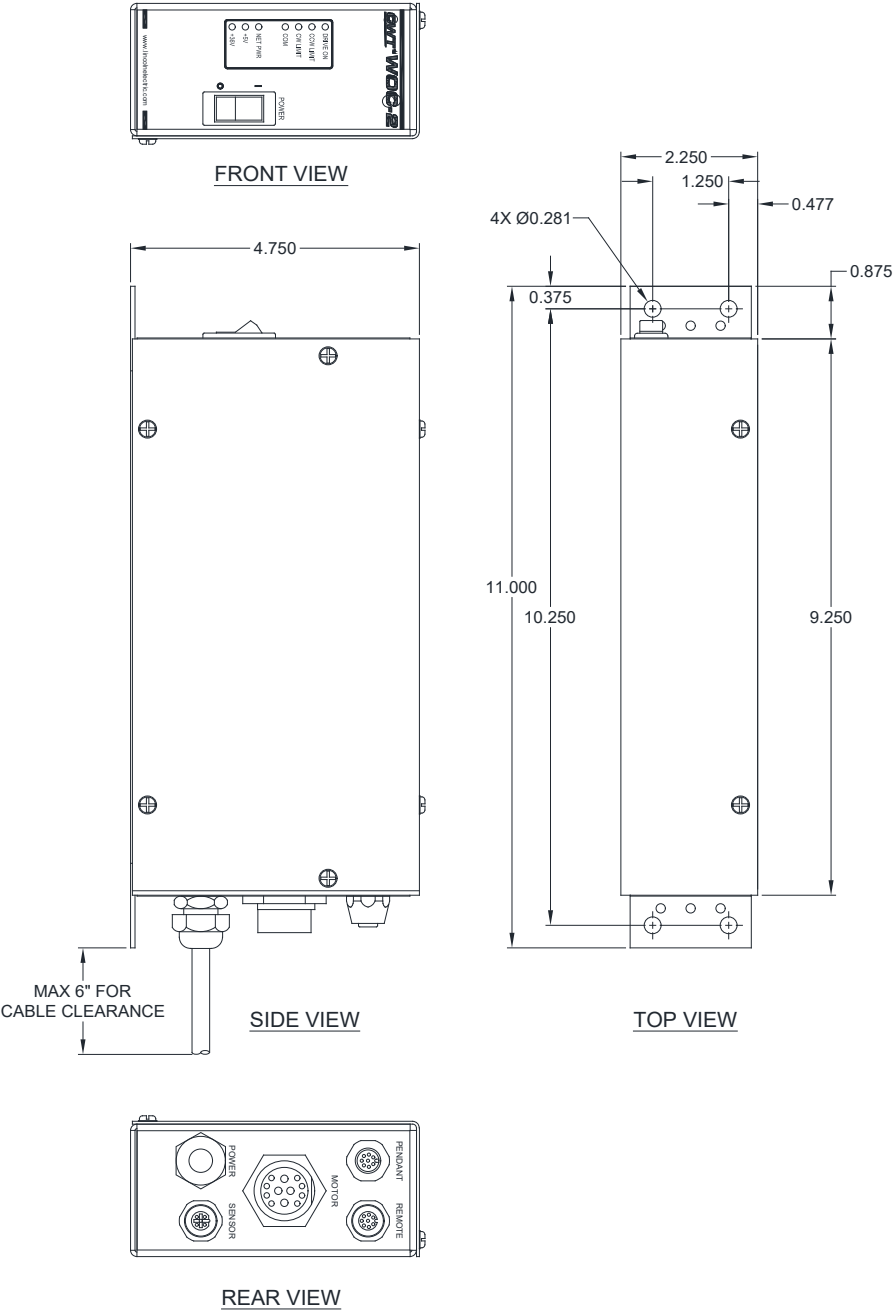

FIG 2-2: WOC-2 Control Enclosure Mounting Dimensions

Figure 2-3 shows the dimensions for the Operator Pendant.

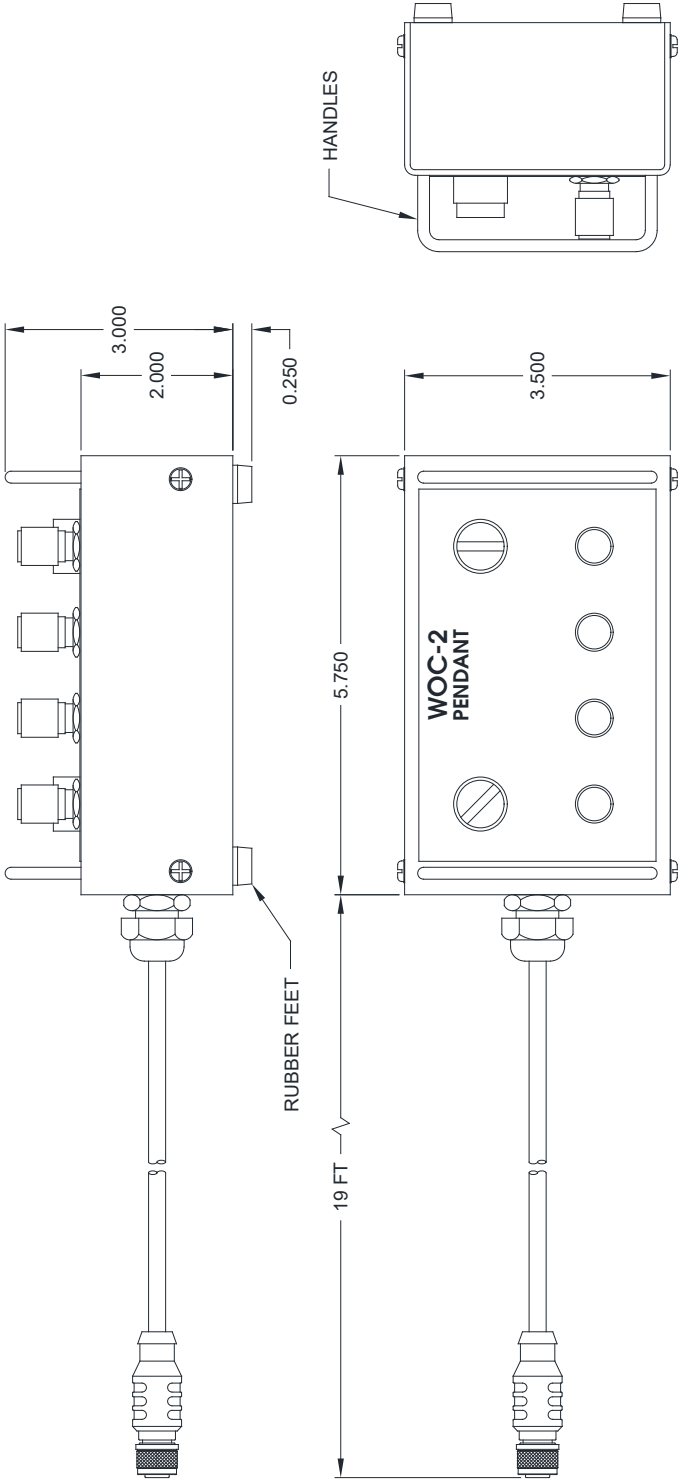

FIG 2-3: Operator Pendant Dimensions

2.2 CABLES

Connect a suitable source of 115-vac power to the power input connector using a power cable. Refer to Appendix A for power cable connection information for the power cable assembly. Connect the stepper motor drive cable (CWT P/N S3W5034) to the motor connector on the rear panel. The maximum motor cable length is 75 ft. Refer to Appendix A for motor control cable connection information. Connect the operator pendant cable to the COMM connector on the rear panel.

Warning: *Do not connect or disconnect the stepper motor cable with power applied to the WOC-2 controller.*

If the controller is being used with an external Master Modbus Controller in place of the operator hand pendant then connect the RS-485 cable to the RS-485 COMM connector on the rear panel. Connect the other end of the cable to the Modbus Master RS-485 serial port. (*Note: See section 4.0 for Modbus Communications Information*)

2.3 OPERATION

To operate the WOC-2 controller turn the power switch to the on position. The power switch should illuminate indicating ac power is supplied to the control. The three (3) lower LED's should illuminate indicating the WOC-2 power supplies are operation. The "COMM" LED will pulse from green to red indicating communications between the pendant and the WOC-2 controller. When the WOC-2 controller is powered up the Stepper motor drive power is disabled. Before using the control functions the user must initialize the Slide. Before initializing the WOC-2 make sure that the oscillation slide is free to move.

To initialize the pendulum oscillator toggle the "RUN" switch on the pendant to the "ON" position. The "DRIVE ON" LED will illuminate indicating power has been applied to the motor. After the slide is initialized use the "JOG" switch to move the slide to the desired oscillation center position, use the "SPEED" control to set the desired oscillation and jog speed. Use the "WIDTH" control to set the oscillation width. Use the "LEFT" Dwell to set the left (CCW) position delay time. Use the "RIGHT DWELL" to set the right (CW) position oscillation delay time. To start the oscillation turn the "RUN" switch to the "ON" position. To jog the oscillation center position set the "JOG" switch to the "CW" or "CCW". The Oscillation center position will be moved in desired direction. If the JOG switch is held in the "CCW/CW" position the oscillation center position will updated every 0.1 seconds until the switch is released. If the oscillation pattern reaches it maximum slide position the "JOG" function will be terminated in that direction.

Note: The "RIGHT (CW)" and "LEFT (CCW)" position refer to the motion when facing the front of the pendulum oscillator.

The WOC-2 controller uses a stepper motor drive system. The controller determines the pendulum oscillator's position by tracking the number of steps required to move to a specific location. If the pendulum oscillator cannot move due to some obstruction the stepper motor will enter a stall condition and the WOC-2 controller will lose its positional information. The WOC-2 and drive motor will not be damaged under this condition. However the WOC-2 controller should be powered cycled and reinitialized after clearing the stall condition.

2.4 USER I/O CONTROLS

The control also provides a user I/O interface for remote control of the WOC. There are two isolated Solid State Relay (SSR) outputs CR1 (READY) and CR2 (OSC ON). There are two Isolated inputs INP1 (OSC ON) and INP2 (INITIALIZE) can be used to remote activate the Oscillator and to reinitialize the slide. The SSR outputs are rated at 28 VDC @ 100ma and the inputs are rated at 12 – 28 VDC @ 10 ma. The inputs and outputs provide galvanic isolation from the WOC controller. There are two separate

commons for the two inputs and outputs. The WOC also provides a non-isolated 24 VDC @ 100 ma source that can be used to operate the WOC I/O.

The following is a functional description of the WOC 2 I/O:

- **INP1** – When activated this “OSC ON” input will start the oscillation cycle. When deactivated the oscillation will be stopped. If the oscillation was started with the operator pendant then this input is ignored.
- **INP2** – When activated this input will reinitialize the slide. This input is only active when not jogging or oscillating the slide.
- **CR1** - This “READY” output is active when the WOC controller is initialized and ready for normal operation.
- **CR2** – This “OSC RUN” output is active when the oscillator is active. It will remain active while the “RUN” switch or the remote INP1 is active. “OSC RUN” will remain active until the slide has returned to the oscillation center position.

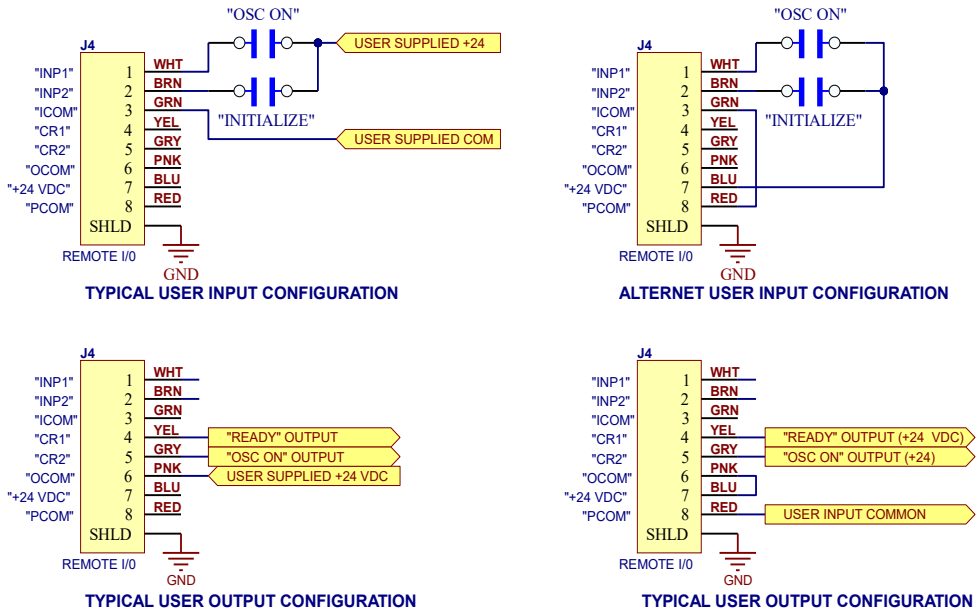
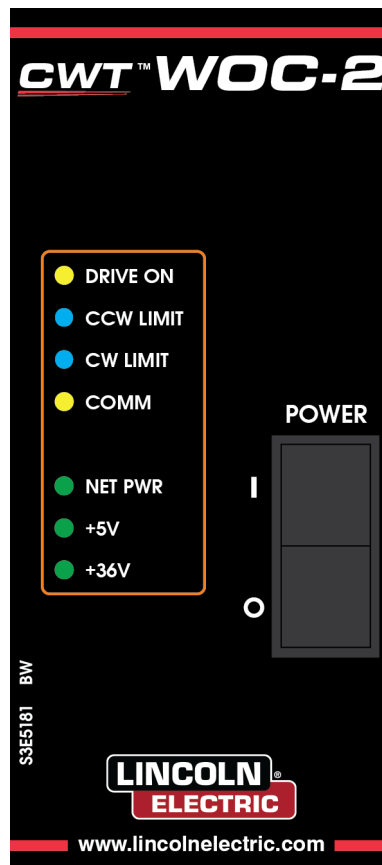

Fig 2-4: Users I/O Configuration

2.5 USER CONTROLS AND STATUS LED'S

The following is a description of the user control function and status LED's found on the WOC-2 motor control enclosure:

- **DRIVE ON** – Indicates when power has been enabled to the pendulum oscillator motor.
- **CCW LIMIT** – This LED is not used with pendulum oscillator.
- **CW LIMIT** – This LED is not used with pendulum oscillator.
- **COMM** – This LED indicates the status of the isolated RS-485 serial communications. A green LED indicates no communications and a RED led indication active serial communication.
- **NET PWR** – This LED indicates that the isolated RS-485 communications port has power applied.
- **+5V** – This LED indicates that the five volt power supply is functioning.
- **+36V** – This LED Indicates that the motor power supply is functioning
- **POWER** – This switch is used to activate the WOC-2 controller.



The following is a description of the user control function found on the WOC-2 operator pendant enclosure:

- **RUN** - This switch is used to start and stop the oscillation cycle. It is also used to initialize the pendulum oscillator when the WOC-2 controller is power up. Setting the switch to the "ON" position will start the oscillation cycle. Setting the

switch to the "OFF" position will terminate the oscillation cycle. When stopping the oscillation cycle the slide will move back to the current oscillation center position. When starting an oscillation cycle the slide will always move to the CCW (Left) position first then return to the CW (Right) position.

- **JOG** – This switch is used position the slide to the desired center position. When not oscillating and the switch is set to the "CCW" position slide will be move in the CCW (Left) direction. When the switch is set to the "CW" position the slide will be moved in the CW (Right) direction. If for some reason the slide has been stalled or is no longer in the correct position the user can hold the switch in the CW direction until the CW limit has been set. This will reset the WOC-2 control to the max position of the slide.
- **SPEED** – The speed pot is used to control the speed of the slide. The actual speed range will be determined by the mechanical slide assembly used with the WOC-2 controller.
- **WIDTH** – The control will set the width of the oscillation pattern. The actual width range will be determined by the mechanical slide assembly used with the WOC-2 controller.
- **LEFT DWELL** – This control sets the Left (CCW) oscillation position delay time. The time range is adjustable from 0.05 to 2.00 seconds.
- **RIGHT DWELL** – This control sets the Right (CW) oscillation position delay time. The time range is adjustable from 0.05 to 2.00 seconds.



2.7 STEPPER MOTOR INTERFACE

The WOC-2 is designed to use any 2-phase stepper motor with a current rating of 1.0 – 6.5 amps. The following is an example of how to interface a 2 phase stepper motor to the WOC-2 controller:

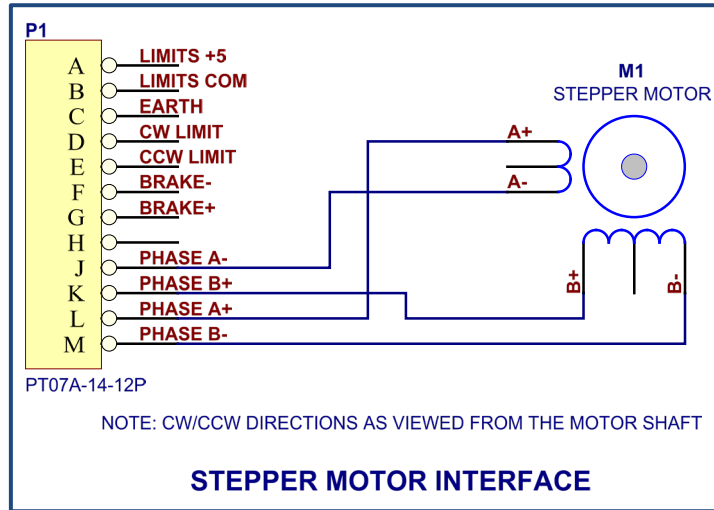

FIG 2-5: Stepper Motor Interface

3.0 WOC-2 OFF-LINE SERIAL TERMINAL PROTOCOL

3.1 COMMUNICATION SELECTION

The WOC-2 is designed for use with a standard RS-485 serial port using ASCII serial commands. It can also be configured to use Modbus RTU protocol over the RS-485 serial port. Only one mode of communications can be enabled at a time. The WOC-2 is configured at the factory for Modbus communication with a specific axis drive. A label is placed on the back panel of the WOC-2 that indicates the current factory setting by AXIS DRIVE NUMBER. The Mode of communications is determined by the setting of S1 Dip switch and the JP5- A & B jumpers located on the Drive CPU P.C. Board.

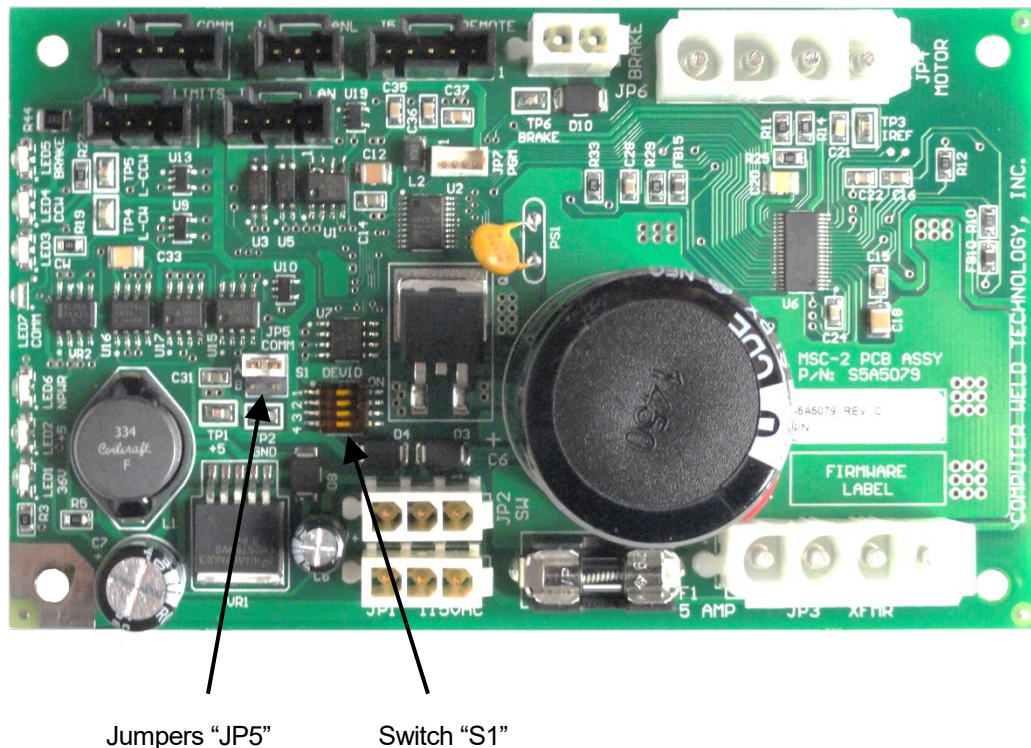

FIG 3-1 – S1 Switch and Jumper Locations

*Note: When setting the **Dip Switches of S1** the following applies:
If the Switch is pressed towards the **NUMBER** side of S1 the Switch is in the **CLOSED** position.*

To enable **RS-485 ASCII Protocol Serial Port Communication** with the WOC-2, use the following procedures:

- Step 1. Remove power to the WOC-2
- Step 2. Remove the cover to the WOC-2
- Step 3. Locate S1, JP5 on the P.C.B. of the WOC-2 (see Figure 4-1)

- Step 4. Set all the S1 Dip switches to the **CLOSED** position. The Switches are in the **CLOSED** position when they are set to the **NUMBER** side of S1.
(See Figure 4-1)
- Step 5. Move JUMPER on JP5 to the A position.
- Step 6. Replace the cover on the WOC-2.
- Step 7. Connect an RS-485 cable to the COM connector on the rear of the WOC-2 and using a RS-485 driver connect to the computer terminal program.
- Step 8. Apply power to the WOC-2.

The WOC-2 is ready to accept commands from the computer terminal via the RS-232 cable. **See Section 4.3 through 4.5 for RS-485 communications programming and a list and description of commands.**

3.2 RS-485 COMMUNICATIONS ASCII PROTOCOL

The RS-485 ASCII communications port is used to off-line program the operating parameters for the WOC-2. The Protocol is simple ASCII command strings that allows the user to up-load or download the various parameters. The serial port is configured for the following data format:

<i>Baud Rate:</i>	<i>19,200 Full Duplex</i>
<i>Word Length:</i>	<i>8 Data Bits, One Stop and no parity</i>
<i>Hand Shaking:</i>	<i>None</i>

3.3 PORT PROTOCOL

The Protocol consists of a command string and optional data bytes. The command string is an Alpha character and option number followed by a "=" or "?" followed by optional data and terminated with an ASCII "cr" (0dh). The "=" will indicate that data is being sent to the select parameter by the host controller. The "?" will indicate a request for data from the WOC-2 to the Host controller. If the host is up-loading data to the WOC-2 the data will be placed after the "=" character and will be an ASCII string terminated with an ASCII "cr" (0dh). The following is an example of sending a new V1 value to the WOC-2:

V1=1000(cr) - Sent from Host

To read the V1 parameter in the WOC-2, send the following command:

<i>V1?(cr)</i>	<i>- Sent from Host</i>
<i>1000(cr)</i>	<i>- Received from WOC-2</i>

If an invalid command or values is entered then one of the following error messages will be sent to the host terminal.

<i>Error - Invalid Command</i>	<i>- Sent from Host</i>
<i>Error - Invalid Parameter</i>	<i>- Sent from Host</i>
<i>Error - Invalid Command Value</i>	<i>- Sent from Host</i>

3.4 TERMINAL COMMANDS

The following is a summary of the RS-485 ASCII serial Commands supported by the WOC-2:

COMMAND	DESCRIPTION
A1	Analog Command Table: A1 = Read Motor current DAC reference
M0-M6	Mode Read Write Commands M1= Read Modbus Coils CR1..CR8 (Outputs)
Bit	Function
0	Drive Ready
1	Moving to Position
2	Drive Motor Power enabled
3	Right Dwell Bit
4	Auto Execute Command Running
5	Drive Fault
6	Slide Home Routine is Active
7	Left Dwell Bit
	M2 = Read/Write Modbus Coils CR9..CR16 (Inputs)
BIT	Function
0	Enable Drive
1	Home Slide
2	Halt Move
3	Index CW
4	Index CCW
5	Enable Weave Mode
6	Save Default Configuration data in Flash memory
7	Rest WOC-2 PWM drive controller
	M3 = Read/Write Modbus Coils CR17.. CR24
Bit	Function
0	Not Used
1	Not Used
2	Not Used
3	Not Used
4	Not Used
5	Not Used
6	Not used
7	Not Used
	M4 = Read/Write Modbus Coils CR25.. CR32
Bit	Function
0	SW1 - 1 Device Address Bit 1
1	SW1 - 2 Device Address Bit 2
2	SW1 - 3 Device Address Bit 3
3	SW1 - 4 Devive Address Bit 4
4	Device Address Bit 5 (DevID 17 – 23)
5	Device Address Bit 6 (DevID 33-39)

- 6 Enable MWC II LAN protocol (LAN33–LAN39)
- 7 Enable Original MWC LAN protocol (81 – 86)

V1 – V20 Variable command Parameter:

- V1 = Step Motor Speed (#####) steps/sec
- V2 = Oscillation Width (In Steps)
- V3 = Right Dwell Time (### seconds)
- V4 = Left Dwell Time (### seconds)
- V5 = Current Position MSB:LSB2
- V6 = Current Position ISB1:LSB
- V7 = Move Position MSB:LSB2
- V8 = Move Position ISB1:LSB
- V9 = Max Position MSB:LSB2
- V10 = Max Position ISB2:LSB
- V11 = Home Speed
- V12 = MSB:LSB MSB=Mode, LSB=Motor Current
- V13 = MSB:LSB where MSB=Accel/Decel, LSB=Scale
- V14 = Oscillation Left Position
- V15 = Oscillation Center Position
- V16 = Oscillation Right Position
- V17 = Spare 1
- V18 = Spare 2
- V19 = Spare 3
- V20 = MSB:LSB where MSB=FDtime , LSB=Toff

4.0 WOC-2 MODBUS MEMORY MAP

4.1 General Description

This document provides the basic Modbus memory map and command structure for the WOC-2 RS-485 communications port. The WOC-2 supports the Modbus Protocol as specified in the Modicon Technical publications “Modbus Protocol” (intr7.html). The WOC-2 control does not support the Broadcast mode. The controller provides the slave side communications routines for the RTU mode. The user must define the Slave ID to a unique ID number from 1 – 247. Default Baud rate is 19.2 K baud. To enable the Modbus Protocol set a Slave ID on SW1 with the mode Jumper JP5 in the A position. After setting the Device ID on SW1 power cycle the WOC-2 to enable the Modbus Slave RTU protocol. The default baud rate is 19.2, No Parity, One Stop bit.

4.2 Supported Modbus Commands

The following ModBus commands are supported:

CODE	DESCRIPTION	ADDRESS RANGE
01	Read Coil Status	0-31
03	Read Holding Registers	0-21
05	Force Single Coil	0-15
06	Preset Single Register	0-21
15	Force Multiple Coils	0-15
16	Preset Multiple Registers	0-21
17	Report Slave ID	5 bytes

4.3 Memory Map for Coils (Modbus Command 01,05,15)

The following is the Coil definitions address 0-31:

COIL	ADDRESS	DESCRIPTION
1	0	Drive Ready Output (1=Ready, 0= Not Ready)
2	1	Moving to Position Output (1=Active, 0=Move complete)
3	2	Drive Power On Output (1= On, 0 = off)
4	3	Right Dwell Active Output (1=Active, 0=Off)
5	4	Auto Execute Function Active Output (1=ON, 0=Complete)
6	5	PWM Drive Fault Output (1=Fault, 0=No Fault)
7	6	Home Slide Active Output (1=Active, 0 = Complete)
8	7	Left Dwell Active Output (1=Active, 0=Off)
9	8	Enable Drive Input (1= Enable)
10	9	Home Slide Input (1=Home Slide)
11	10	Halt Move Input (1=Halt)
12	11	Rotate CW Direction (1= ON)
13	12	Rotate CCW Direction (1=ON)
14	13	Enable Oscillation Input (1= Osc On, 0=Osc Off)
15	14	Save Default Configuration Input (1=Save)
16	15	Reset PWM Fault Input (1=PWM Reset)
17	16	CW Position Limit Output (1=Limit Active)
18	17	CCW Position Limit Output (1=Limit Active)

19-24	18-23	Not Defined
25	24	Reverse Home/End Limit
26	25	Auto Brake on @ Power Off
27-28	26-27	Device ID SW1-1 thru SW1-4
29	28	Enable Modbus Address Range 17 to 23
30	29	Enable MWC II LAN Address Range 33-39
31	30	Enable Modbus Range 65-71
32	31	Enable MWC LAN Device ID 81-87

4.4 Coil Definitions and Operation

The WOC-2 has 32 simulated output coils. These coils are used as internal bit flags to perform specific functions. Only 1-18 of the simulated coils is used. Setting the coils 20-24 will not have any effect on the WOC-2 controller. However, they are reserved for future expansion. The WOC-2 supports both single and group force coil commands. Refer to Section 4.3 for summary of the Coil functions. Coils 29 – 32 are used to set the Modbus or CWT LAN ID. ***Warning: Under normal condition do not write to coils 25 - 32.***

4.5 Memory Map for Holding Register (Modbus Command 03, 06, 16)

The following is the Register definitions address 0-19:

REGISTER	ADDRESS	DESCRIPTION
1	0	Motor Speed in steps /msec. (1 - 62535)
2	1	Oscillation Width in Steps (1 - 62535)
3	2	Right Dwell Time in 0.01 seconds (0 -62535)
4	3	Left Dwell Time in 0.001 seconds (0 – 62535)
5	4	Not Used
6	5	Currents position in steps (1 – 62535)
7	6	Not Used
8	7	Move to Position in steps (1 – 62535)
9	8	Not Used
10	9	Max Position in steps (1 – 62535)
11	10	Homing Slide Speed in Steps/msec. (100 – 62535)
12	11	MSB:LSB where MSB = Mode and LSB = Motor Current. Mode = 0 and Current is in 0.1 amp increments (15 – 65)
13	12	MSB:LSB where MSB = Accel/Decel (10 -255) and LSB = position scaling in Steps/step (1 – 255).
14	13	Oscillation Left most position in Steps (1 – 62535) set when Oscillation mode is active (Do Not Modify)
15	14	Oscillation Center position in steps (1 – 62535) set when Oscillation mode is enabled (Do Not Modify)
16	15	Oscillation Right Position in Steps (1-62535) set when the Oscillation mode is active. (Do Not Modify)
17	16	Not Used
18	17	Not Used
19	18	Not Used
20	19	FDtime:Toff stepper motor constant. (DO NOT MODIFY) <i>WARNING: Changing this value may result in a catastrophic failure of the controller</i>

4.6 Coil Definitions and Operation

The WOC-2 has 20 Holding Register. These Holding registers are used as unsigned integers to perform specific control functions. Only 1-4, 6, 8, 10-16 and 20 of the Holding Registers are used. Setting the Registers 5, 7, 9, 17-19 will not have any effect on the WOC-2 controller. However, they are reserved for future expansion. The WOC-2 supports both single and multiple read/write function commands. Refer to Section 4.5 for summary of the Register functions. Under normal conditions, do not write to Register 20. **WARNING: Changing this value may result in a catastrophic failure of the controller**

4.7 Memory Map for Slave ID (Modbus Command 17)

The following is a summary of the Report Slave ID and Status (Code 17) Response Data fields:

Byte	Contents
1	Sensor ID Number =10 Hex (Version 1, Rev0)
2	Run Indicator (0=OFF, FF=On)
3	Status Byte Bit 0 = Ram Full Bit 1 = Battery Ok Bit 2 = Self Test Ok Bit 3-7 = 0
4	Firmware Version Number – BCD Format (MSB = Major: ISB = Minor)
5	Firmware Version Number – BCD Format (MSB+LSB = Release)

5.0 WOC-2 MODBUS CONTROL OPERATION

5.1 General Description

This document provides the basic operational description for the Modbus RS-485 communications port. The WOC-2 supports the Modbus Protocol as specified in the Modicon Technical publications "Modbus Protocol" (intr7.html). The WOC-2 control does not support the Broadcast mode. The controller provides the slave side communications routines for the RTU mode. The user must define the Slave ID to a unique ID number from 1 – 15. Default Baud rate is 19.2 K baud, No Parity, one stop bit. The WOC-2 can be used to control CWT slides or other types of stepper Motor driven slides that use a 2 phase motor with current rating of 1.5 - 6.5 amps/phase.

5.2 Initialization of WOC-2 from Power up

When power is applied to the WOC-2 the Motor drive is disabled and the default configuration is loaded. To activate the Motor drive the follow sequence should be used.

1. Connect suitable host Modbus controller to the RS-485 Comm port and establish communications with the Modus Slave device.
2. Set the Modus Master device to Read 20 Holding Register (Command 0x03) starting at Address 0. This will load the current configuration from the WOC-2 Slave.
3. Set the Modbus Master to read 16 coils (Command 0x01, address 0) starting at address 0. This loads the WOC-2 coils status.
4. If the slide being used has a CCW limit then set Coil 10 (address 9) using command 0x05 or 0x15. This will enable the Motor Drive and set the WOC-2 motor drive to the CCW direction. When the slide reaches the CCW limit the drive will halt the motion then move slowly in CW direction until the slide move off the CCW limit. The MSC will set the current Positon REG[6] to 1 and the COIL 10 will be cleared.

5.3 Move Slide to Position after initialization

Once the Slide has been initialized the user can move the slide to a specific position by writing a speed value to REG[1] (Command 0x06 address 0) then writing a new position into REG[8] (Command 0x06 address 7). The WOC-2 will determine the direction of rotation by comparing the current position to the new Move position. During the move COIL 2 will be set. When the move is complete COIL 2 will be cleared. The user must wait until the move has completed before a new position can be loaded into REG7. To change the move speed write the new speed to REG[1] (Command 0x06 address 0). The speed can be written during a move to position command. Use the following sequence to move the slide to specific location

1. Write Motor speed to REG1 (address 0)
2. Write Slide position to REG[8] (address 7)
3. Wait for Move complete by checking COIL[2](address1). If COIL[2] = 0 then the move is complete.

5.4 Use WOC-2 Oscillator function after initialization

Once the Slide has been initialized the user can writing a speed value to REG[1] (Command 0x06 address 0) . To move the slide to the center position of the write the position into REG[8] (Command 0x06 address 7). Load the Oscillation width into REG[2] (Command 0x06 address 1). If User needs to dwell at the end of each oscillation sweep then write the Right Dwell time into REG[3] (Command 0x06 address 2) and the left dwell time into REG[4] (Command 0x06 address 3). To start the oscillation around the current slide position set COIL[14] (Command 0x05 address 13). The WOC-2 will calculate the Left, Right and Center positions based on the Width set in REG[2] and the current position of the slide. To halt the oscillation clear COIL[14] (Command 0x05 address 13). The oscillation will end when the slide has returned to the starting position. While oscillating the user can write new oscillation width REG[2], oscillation speed REG[1], Right Dwell time REG[3] and left dwell time REG[4]. To change the center position the user needs to Clear COIL[14] to halt the oscillation. When the slide stops at the original center position then a new position can be written to REG[8].

1. Write Oscillation speed to REG[1](address 0)
2. Write Oscillation width to REG[2](Address, 1)
3. Write Right Dwell time to REG[3](Address, 2)
4. Write Left Dwell time to REG[4](Address,3)
5. To start the oscillator write 1 to COIL[14](address 13)
6. To stop the oscillator write 0 to COIL(14)(address 13)

6.0 COMMUNICATION DIAGRAMS

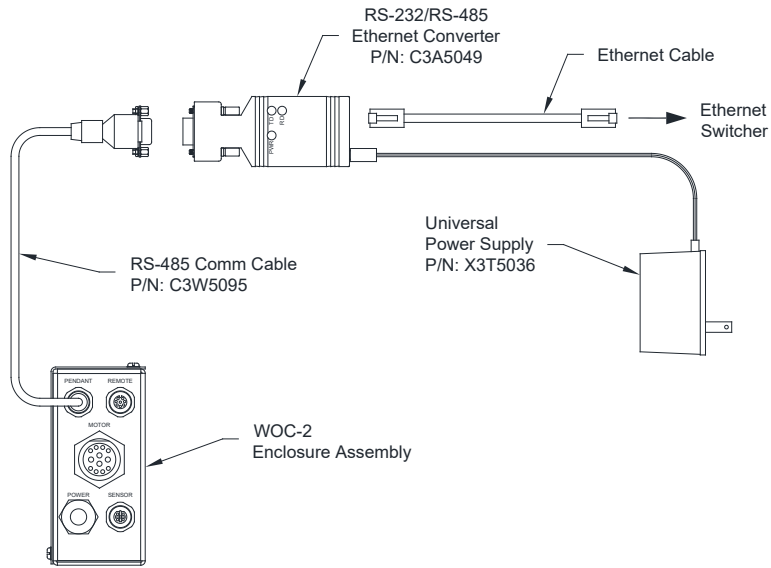

Single WOC-2 Enclosure to an RS-485 to Ethernet Converter Diagram

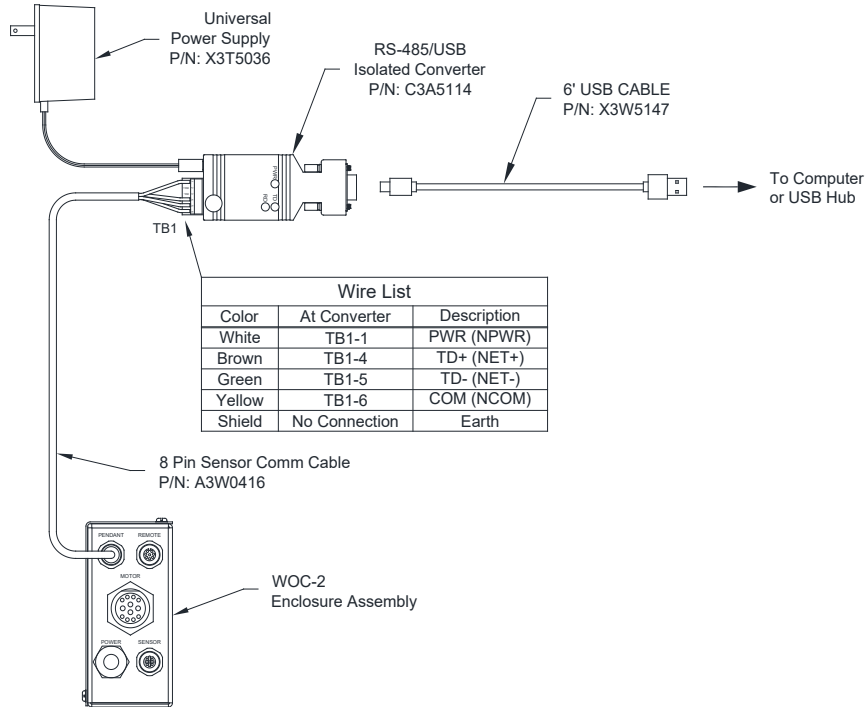

Single WOC-2 Enclosure to an RS-485 to USB Converter Diagram

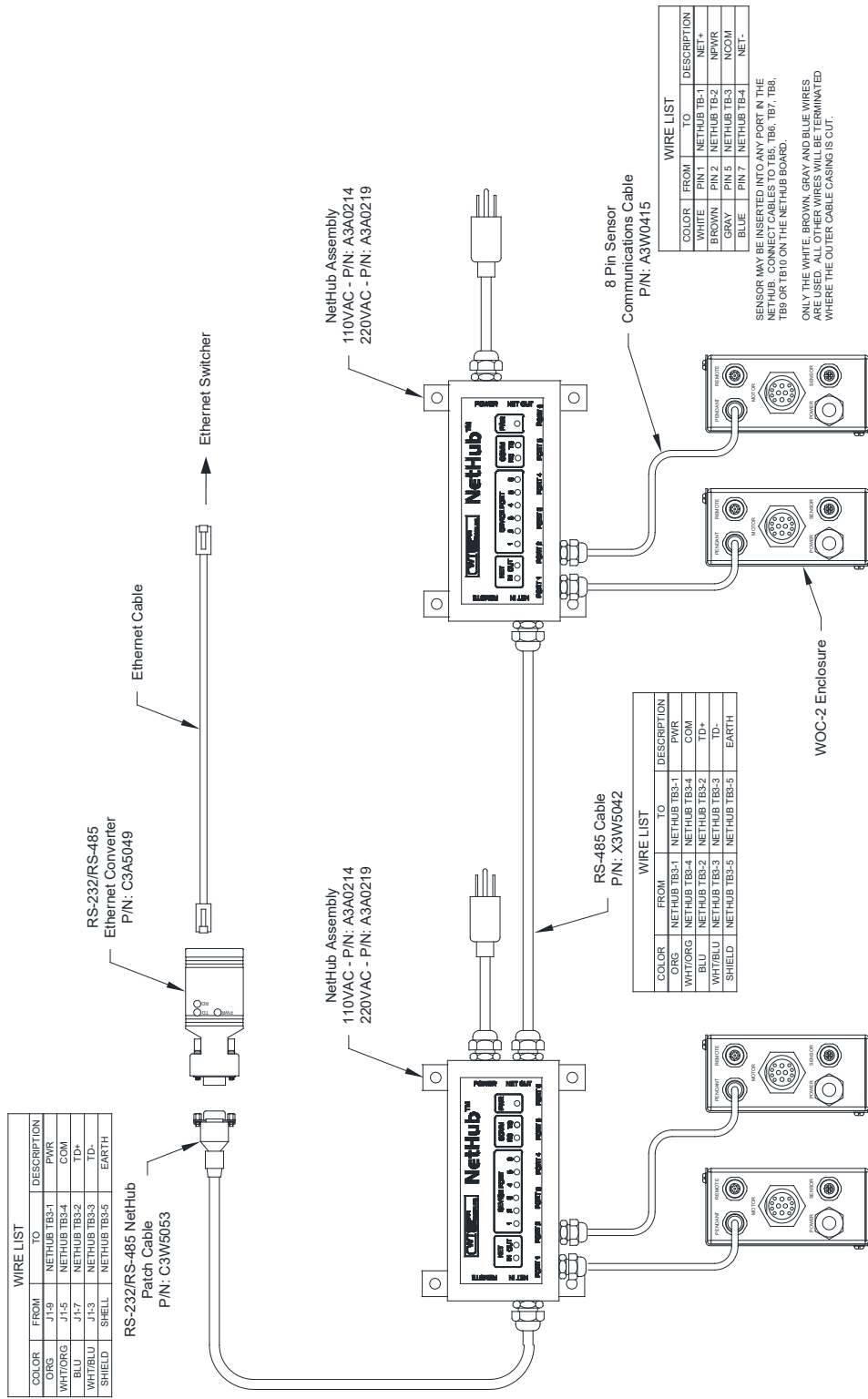

Multiple WOC-2 Enclosure to a NetHub with Ethernet Communications Diagram

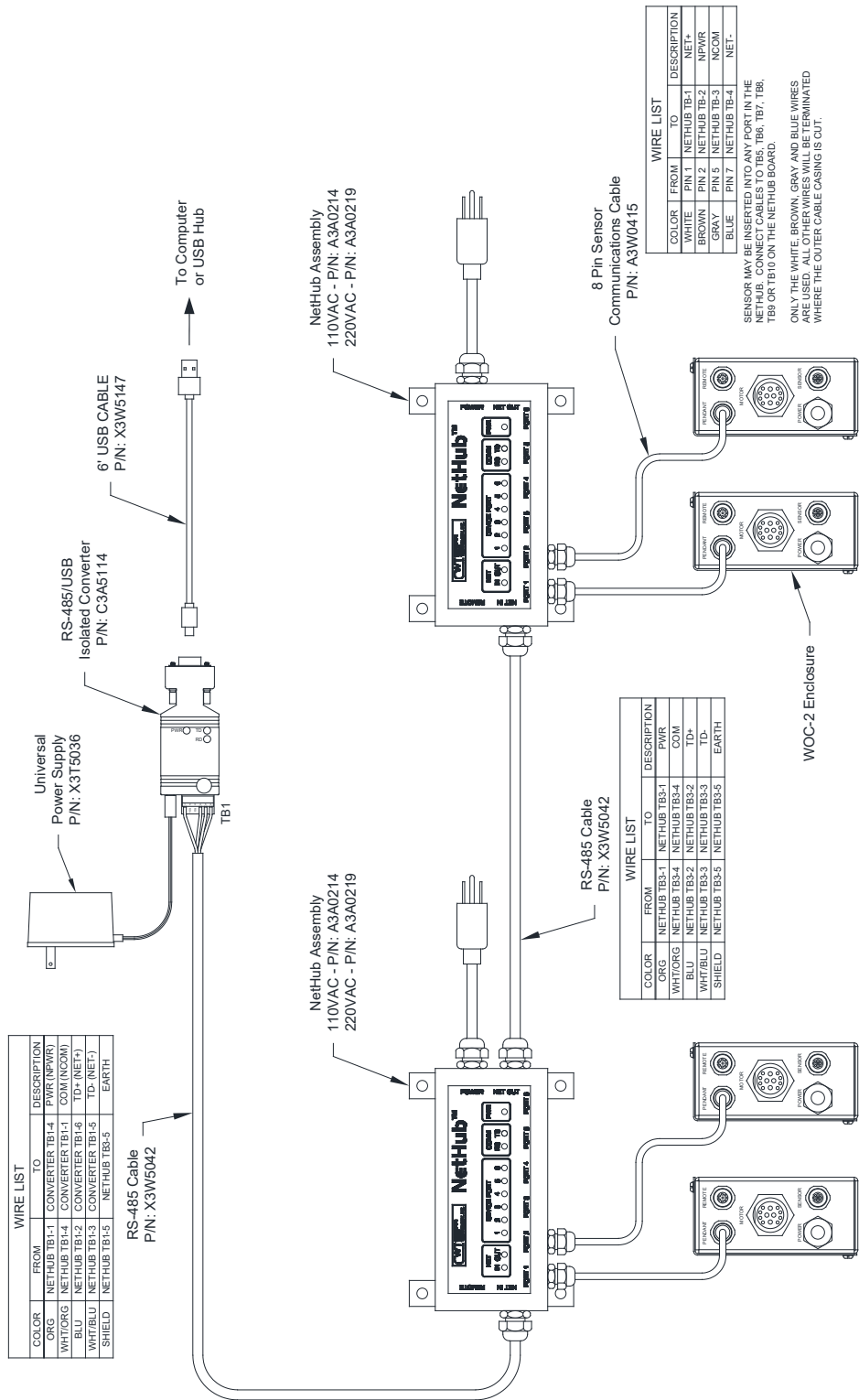

Multiple WOC-2 Enclosure to a NetHub with USB Communications Diagram

APPENDIX A WOC-2 SYSTEM DRAWINGS

A.1 WOC-2 System 110VAC P/N: E0A5023

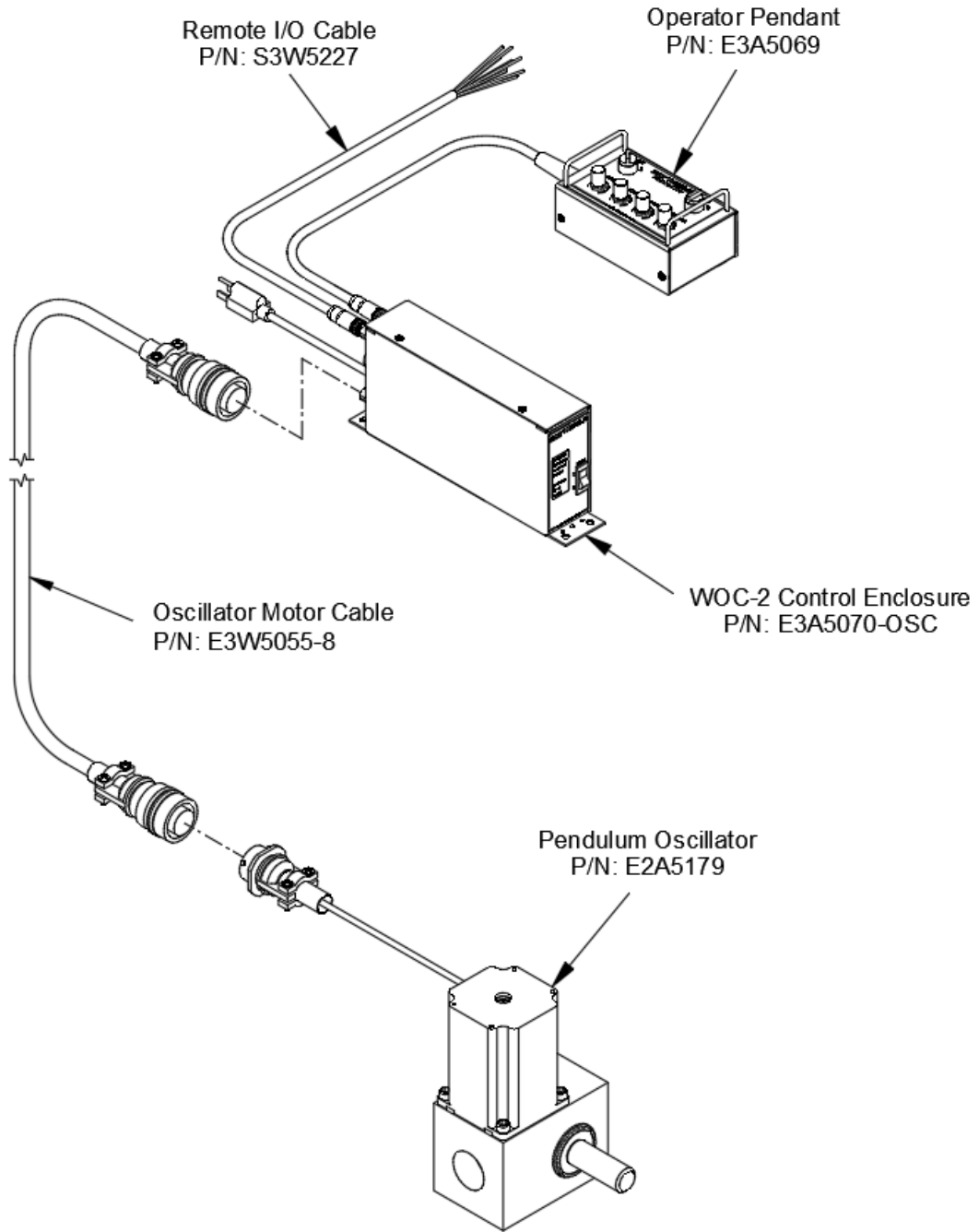

A.2 WOC-2 System 220VAC P/N: E0A5024

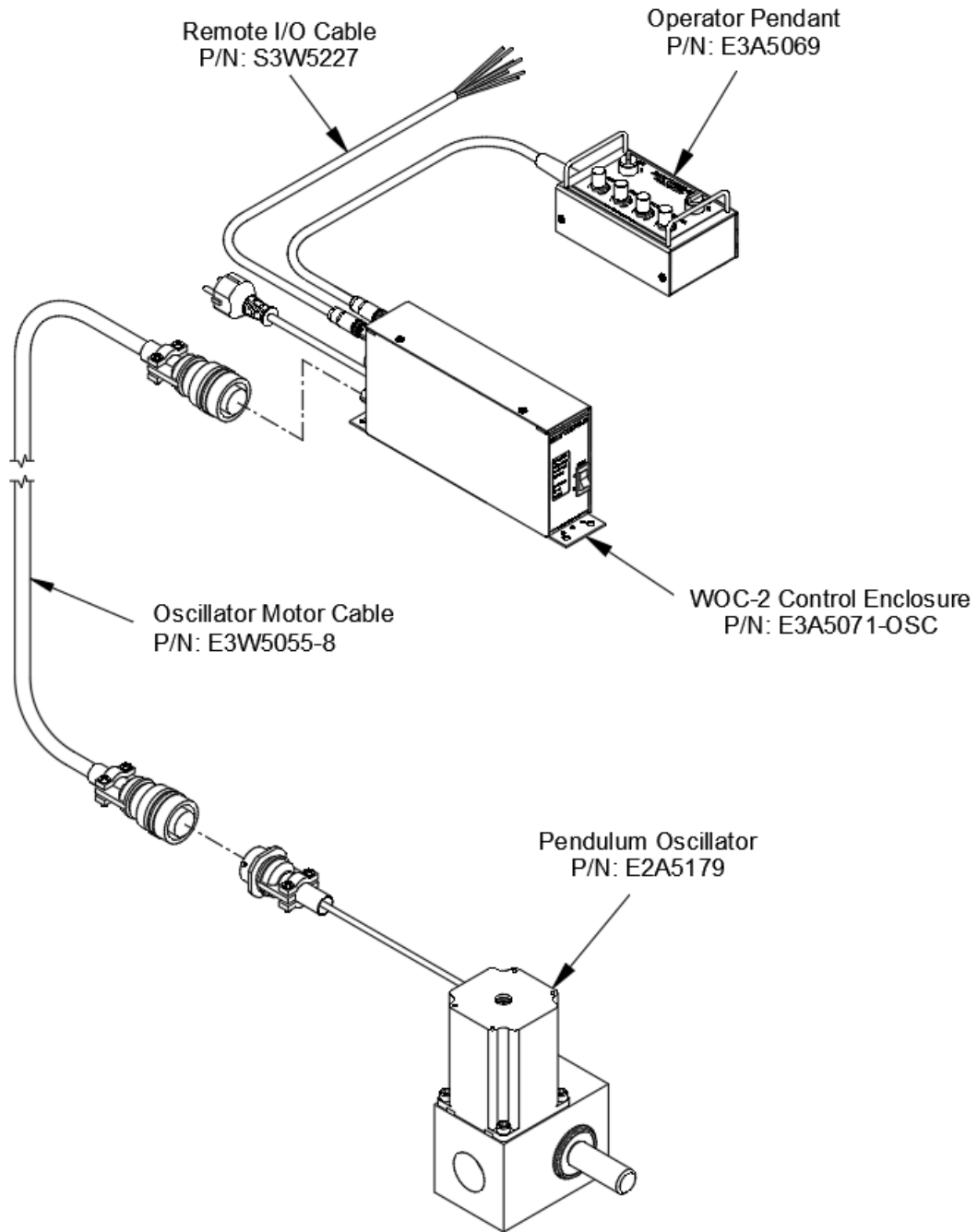

A.3 WOC-2 Enclosure Assembly 110VAC P/N: E3A5070-OSC

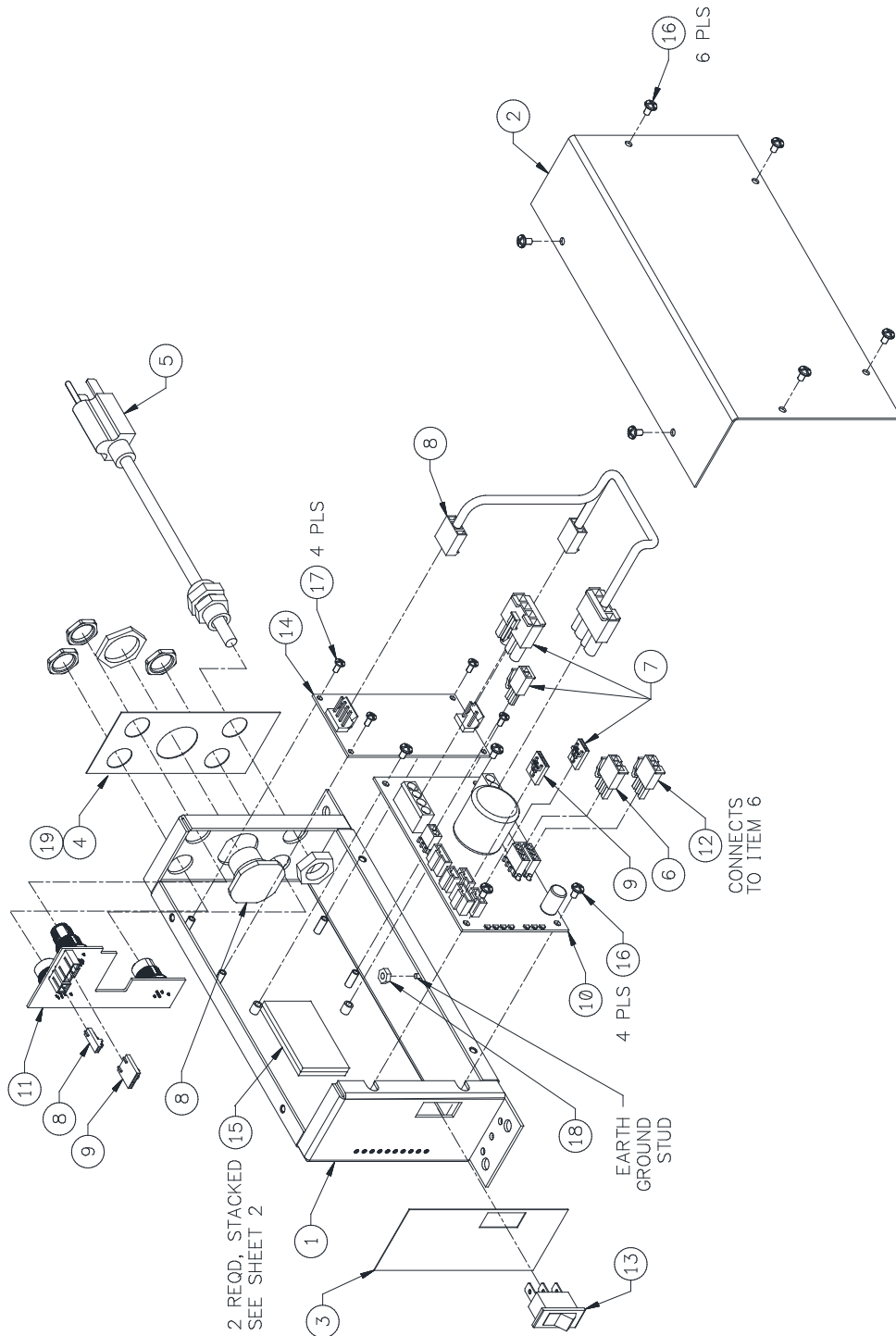

ITEM	QTY	PART NUMBER	DESCRIPTION
1	1	S3E5165	Enclosure
2	1	S3E5166	Cover
3	1	S3E5181	Overlay, Front
4	1	S3E5148	Overlay, Rear
5	1	S3W5159	Cable, American 110vac Power
6	1	S3W5160	Harness, Power Switch
7	1	S3W5169	Harness, Motor
8	1	S3W5224	Harness, Power Supply
9	1	S3W5225	Harness, Comm
10	1	S5A5079	PCB Assembly, MSC-2
11	1	S5A5092	PCB Assembly, ATC III Interface
12	1	X3P5875	Connector, Housing Plug 3 Circuit
13	1	X3S5078	Switch, Rocker
14	1	X3T5095	Supply, Power Ac-DC 24VDC 40W
15	2	S2M5212	Pad, Thermal
16	10		Screw, 6-32 x 1/4" Pan Head w/ Internal Lock Washer
17	4		Screw, 4-40 x 1/4" Pan Head w/ Internal Lock Washer
18	1		Nut, 6-32 Hex
19	1		Label, Serial Number

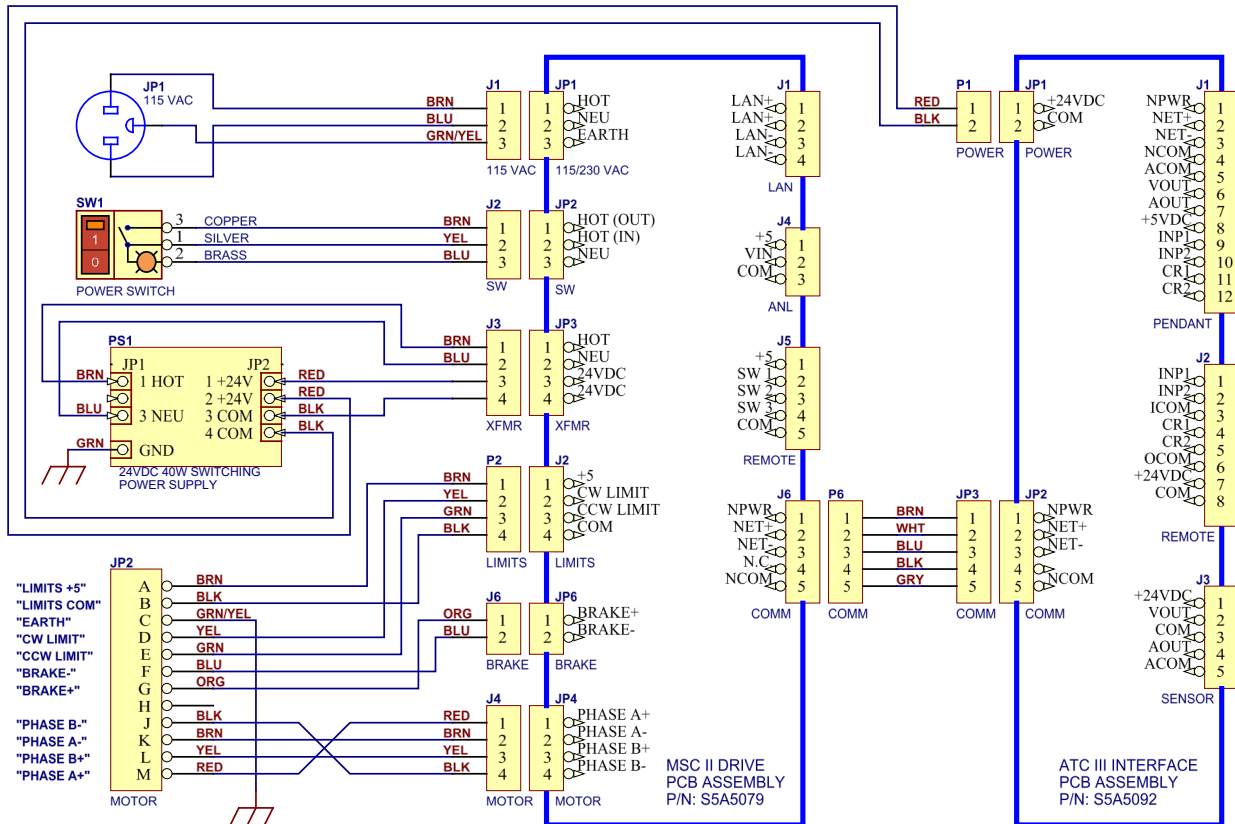

WOC-2 Control Enclosure 110VAC Internal Wiring Diagram

A.4 WOC-2 Enclosure Assembly 220VAC P/N: E3A5071-OSC

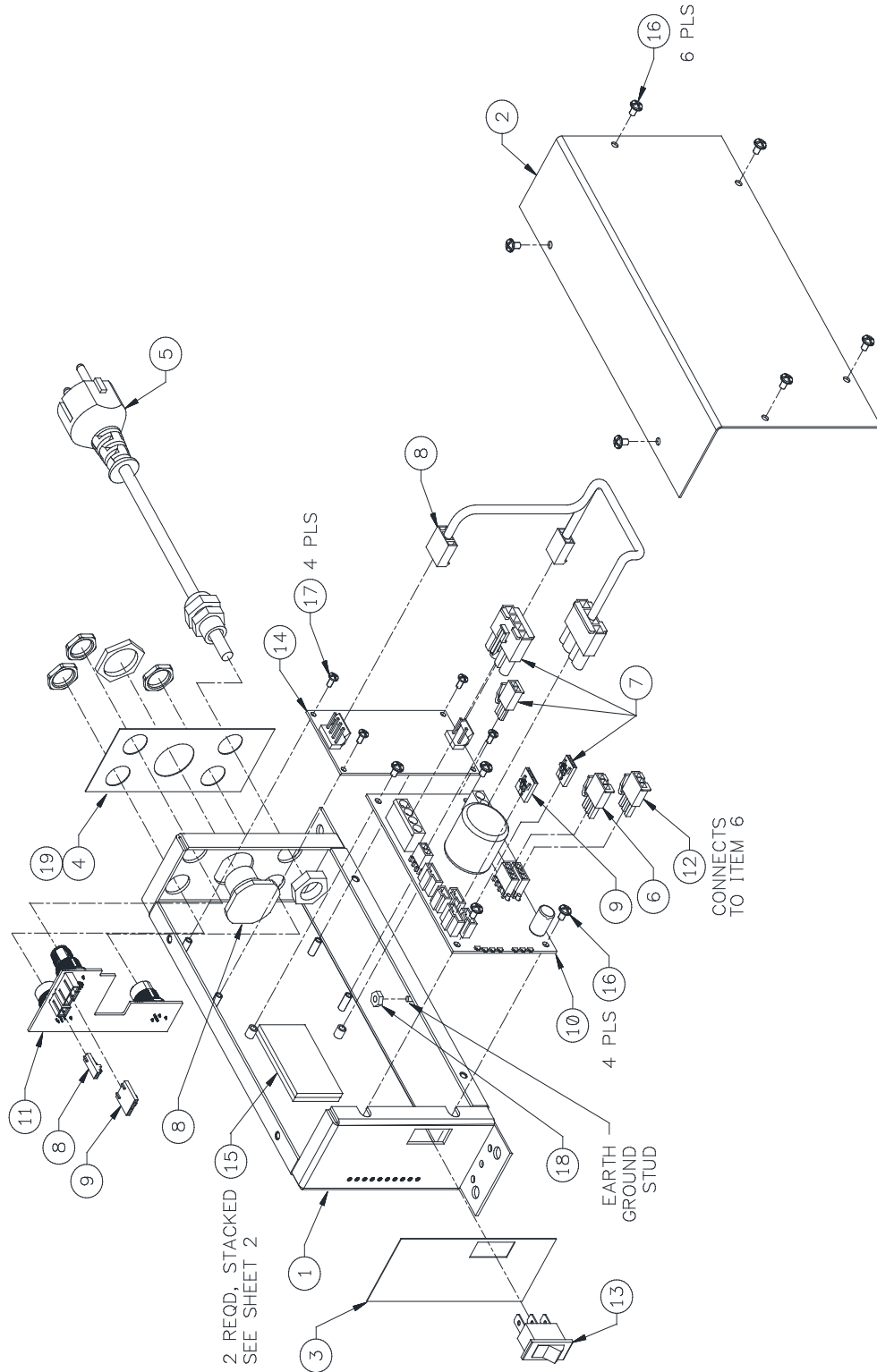

ITEM	QTY	PART NUMBER	DESCRIPTION
1	1	S3E5165	Enclosure
2	1	S3E5166	Cover
3	1	S3E5181	Overlay, Front
4	1	S3E5148	Overlay, Rear
5	1	S3W5171	Cable, European 220vac Power
6	1	S3W5160	Harness, Power Switch
7	1	S3W5169	Harness, Motor
8	1	S3W5224	Harness, Power Supply
9	1	S3W5225	Harness, Comm
10	1	S5A5079	PCB Assembly, MSC-2
11	1	S5A5092	PCB Assembly, ATC III Interface
12	1	X3P5875	Connector, Housing Plug 3 Circuit
13	1	X3S5090	Switch, Rocker
14	1	X3T5095	Supply, Power Ac-DC 24VDC 40W
15	2	S2M5212	Pad, Thermal
16	10		Screw, 6-32 x 1/4" Pan Head w/ Internal Lock Washer
17	4		Screw, 4-40 x 1/4" Pan Head w/ Internal Lock Washer
18	1		Nut, 6-32 Hex
19	1		Label, Serial Number

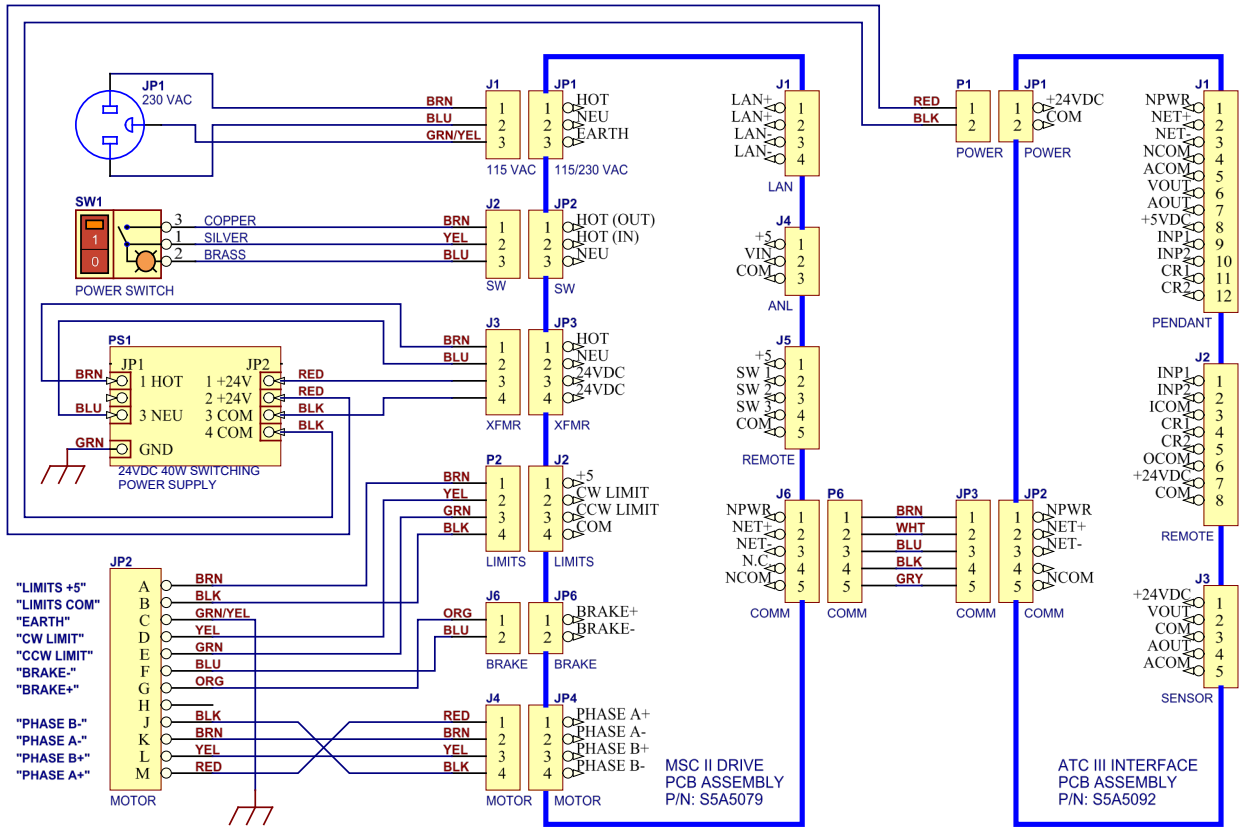

WOC-2 Control Enclosure 220VAC Internal Wiring Diagram

A.5 WOC-2 Operator Pendant P/N: E3A5069

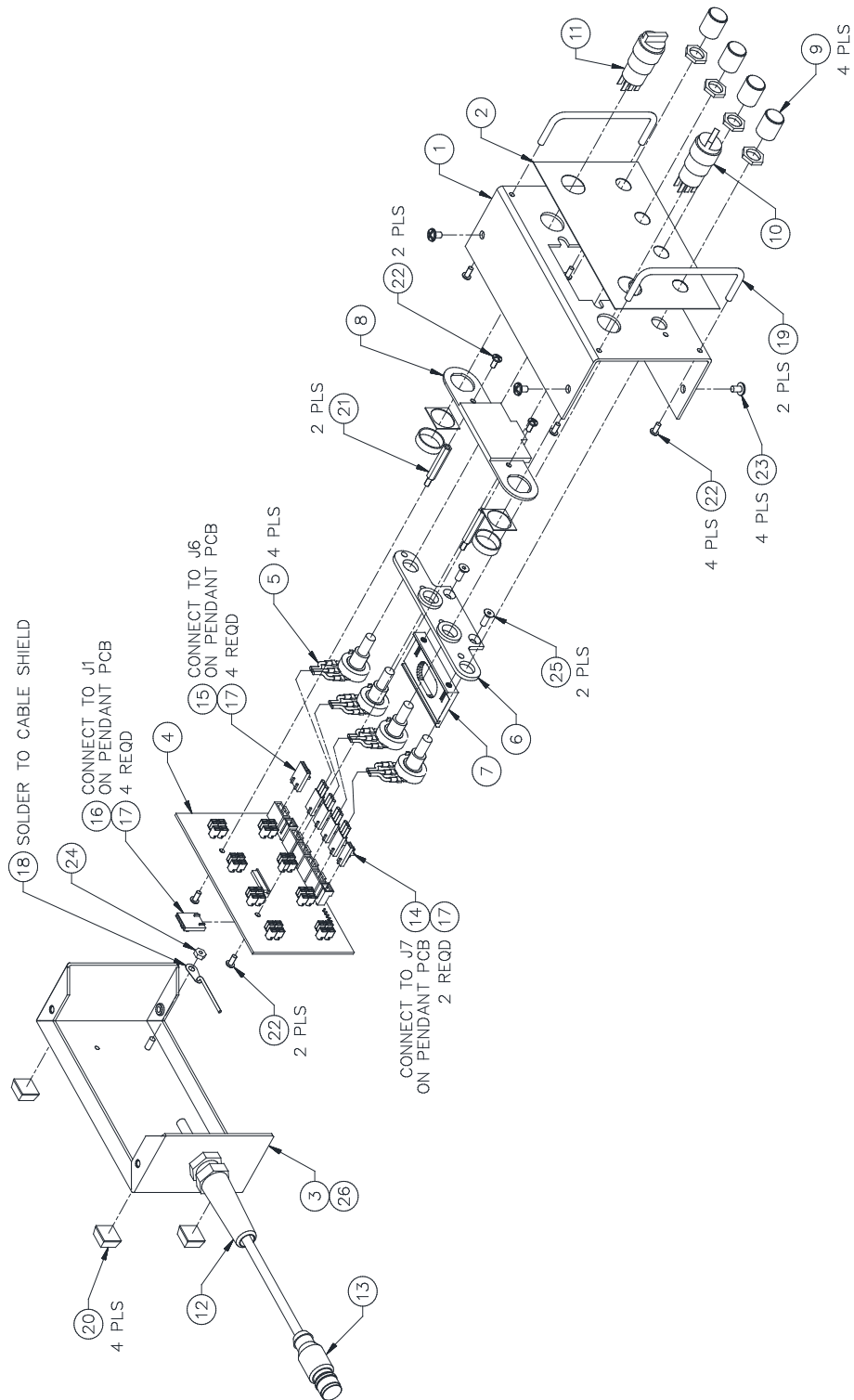

ITEM	QTY	PART NUMBER	DESCRIPTION
1	1	S3E5141	Base, Smart Pendant w/ Display
2	1	S3E5180	Overlay, WOC-2 Smart Pendant
3	1	C3E5008	Cover, Pendant
4	1	S5A5083-WOC2	PCB Assy, Smart Pendant WOC-2
5	1	S3A5224	Pot Assy, Smart Pendant 5K
6	1	E2M5875	Spacer, WOC-2 Pendant Pot
7	1	E2M5876	Support, WOC-2 Pendant PCB
8	1	E2M5877	Spacer, WOC-2 Pendant Switch
9	1	X6A5015	Knob, Black
10	1	X3S5126	Switch, Selector 2 Position Maintained
11	1	X3S5148	Switch, Selector 3 Position Center Maintained
12	1	X3Z5006	Relief, Strain
13	1	X3W5144	Cable, M12 12Conductor Shielded Female Straight Single Ended
14	1	X3P5838	Connector, Housing Plug 2 Circuit
15	1	X3P5839	Connector, Housing Plug 4 Circuit
16	1	X3P5840	Connector, Housing Plug 5 Circuit
17	9	X3P5843	Terminal, Crimp
18	1	X3P5257	Lug, Locking Ring Terminal
19	2	X6A5014	Handle, Black 3" Center
20	4	X6Z5090	Bumper, Black Self-Adhesive
21	2	X6S5026	Spacer, #4-40 x 1" Long Female-Female
22	6		Screw, #4-40 x 1/4" Pan Head w/ Inter Lock Washer
23	4		Screw, #6-32 x 1/4" Pan Head w/ Inter Lock Washer
24	1		Nut, Hex #6-32
25	1		Screw, #6-32 x 3/8" Socket Flat Head
26	1		Label, Serial Number

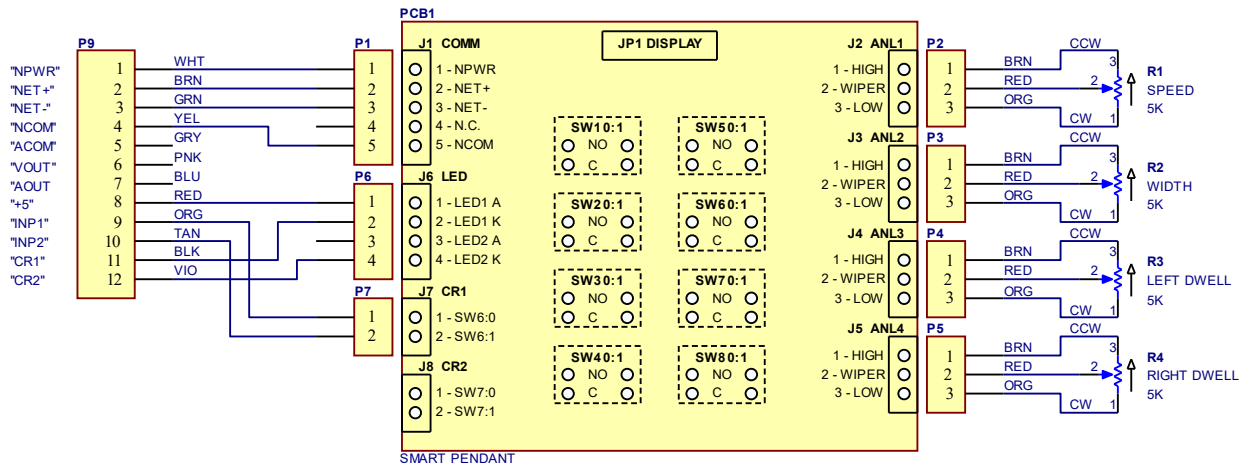

WOC-2 Operator Pendant Internal Wiring Diagram

A.6 REMOTE I/O CABLE P/N: S3W5227

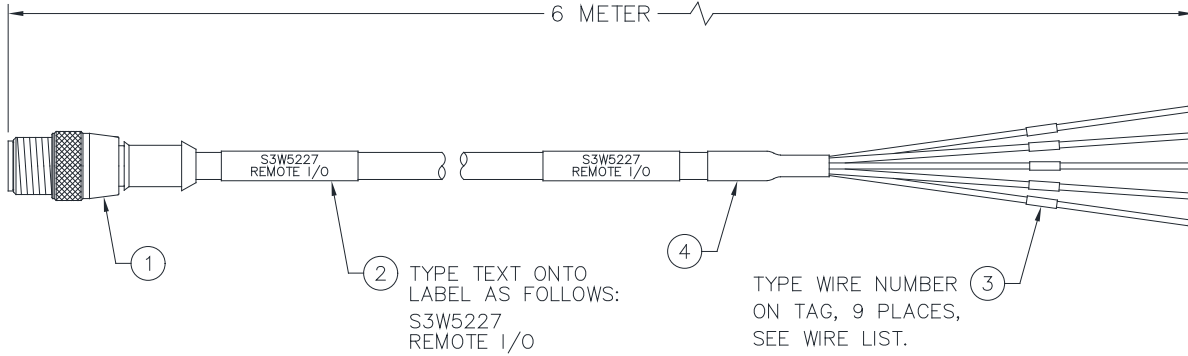

ITEM	QTY	PART NO	DESCRIPTION
1	1	X3W5121	Cable, M12 8 Circuit Male Straight Single Ended
2	2		Sleeve, Cable
3	9		Sleeve, Wire Makers
4	1		Tubing, Black Heat Shrink 3/8" Diameter 1" Long

WIRE COLOR	PIN NO.	REFERENCE
WHITE	1	INP1
BROWN	2	INP2
GREEN	3	ICOM
YELLOW	4	CR1
GRAY	5	CR2
PINK	6	OCOM
BLUE	7	+24VDC
RED	8	COM
SHIELD	BODY	EARTH

A.7 Pendulum Oscillator Assembly P/N: E2A5179

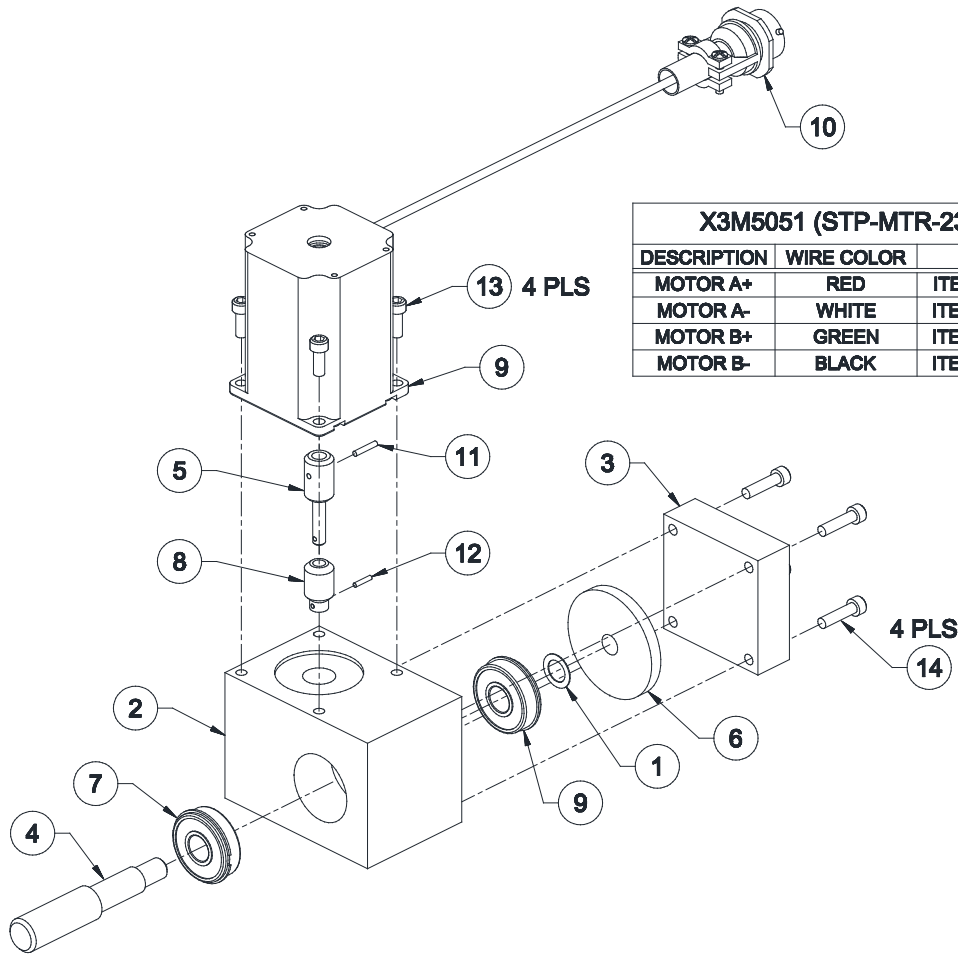

X3M5051 (STP-MTR-2307) WIRE LIST			
DESCRIPTION	WIRE COLOR	FROM	TO
MOTOR A+	RED	ITEM 1 PIN 1	ITEM 3 PIN A
MOTOR A-	WHITE	ITEM 1 PIN 2	ITEM 3 PIN B
MOTOR B+	GREEN	ITEM 1 PIN 3	ITEM 3 PIN C
MOTOR B-	BLACK	ITEM 1 PIN 4	ITEM 3 PIN D

ITEM	QTY	PART NUMBER	DESCRIPTION
1	1	E2M5520	Bearing Spacer
2	1	E2M5798	Housing
3	1	E2M5799	Cover
4	1	E2M5800	Output Shaft
5	1	E2M5801	Adaptor Shaft
6	1	E2M5609	Worm Gear
7	2	X2B5054	Bearing
8	1	X2G5021	Worm
9	1	X3M5034	Stepper Motor
10	1		3/32" Dia. x 1/2" Lg. Roll Pin
11	1		5/64" Dia. x 3/8" Lg. Roll Pin
12	4		#10-32 x 5/8" Lg. Socket Cap Hd. Screw
13	4		#10-32 x 1" Lg. Socket Cap Hd. Screw

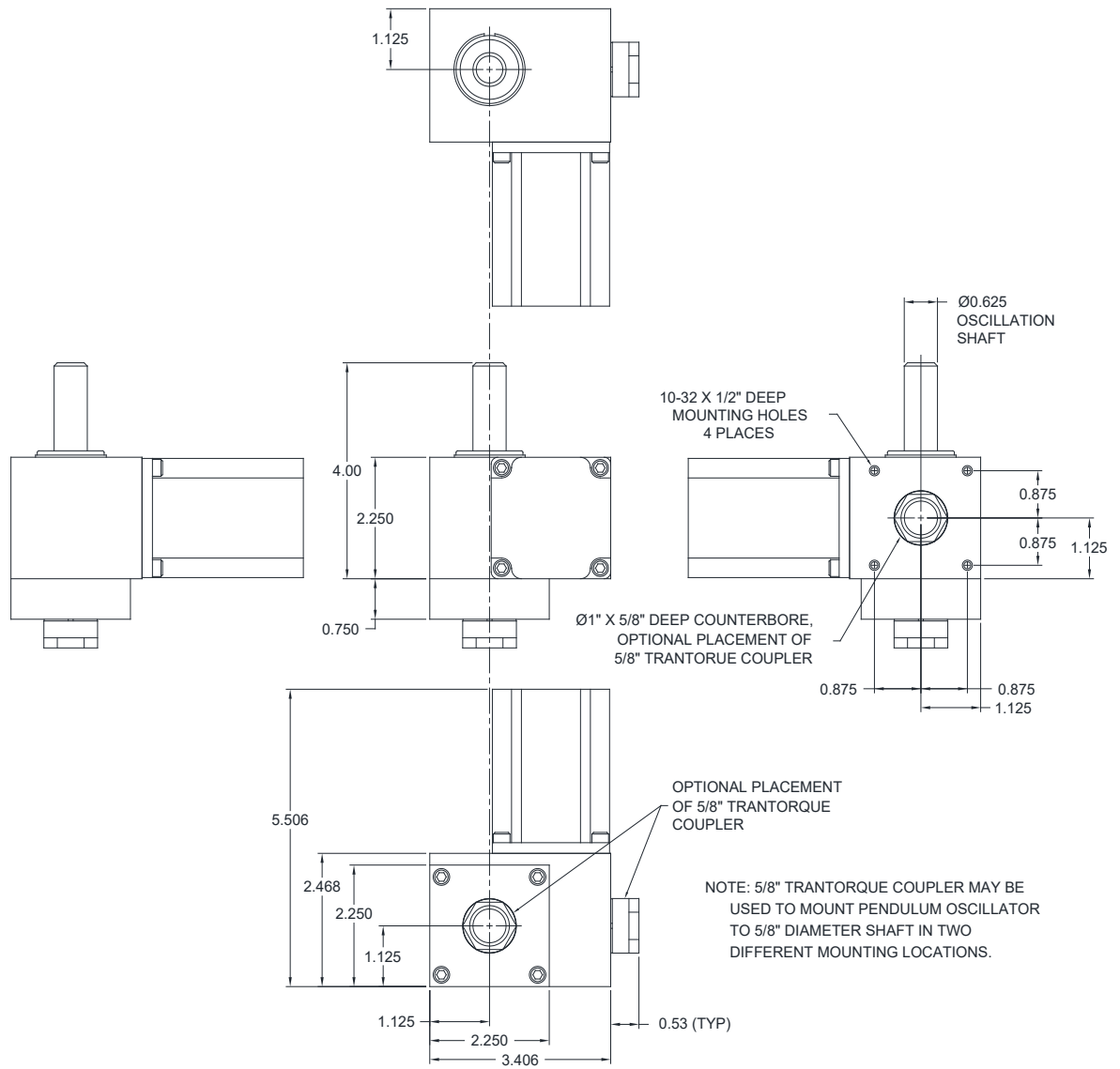

Physical Dimensions for Pendulum Oscillator

A.8 Oscillator Motor Cable P/N: E3W5055-8

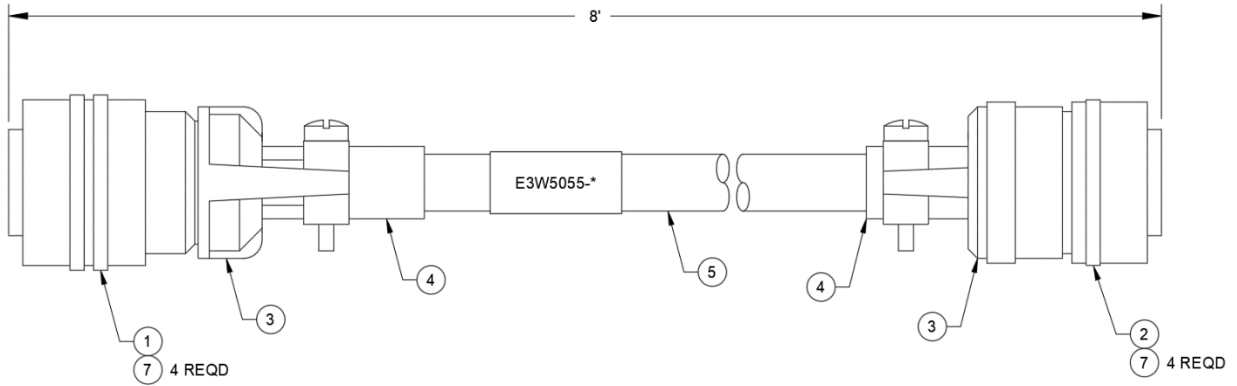

WIRE LIST

DESCRIPTION	WIRE COLOR	FROM	TO
Motor A+	White	Item 1 Pin L	Item 2 Pin A
Motor A-	Red	Item 1 Pin J	Item 2 Pin B
Motor B+	Black	Item 1 Pin K	Item 2 Pin C
Motor B-	Green	Item 1 Pin M	Item 2 Pin D

PARTS LIST

ITEM	QTY	PART NO	DESCRIPTION
1	1	X3P5586	Connector, Plug 12 Circuit Male
2	1	X3P5638	Connector, Plug 5 Circuit Female
3	2	X3P5589	Clamp, Cable
4	2	X3P5505	Boot, Cable Clamp
5	8'	X3W0079	Cable, 4 Conductor 16awg

APPENDIX B ACCESSORIES FOR PENDULUM OSCILLATOR

B.1 Oscillator and Torch Mounting Accessories

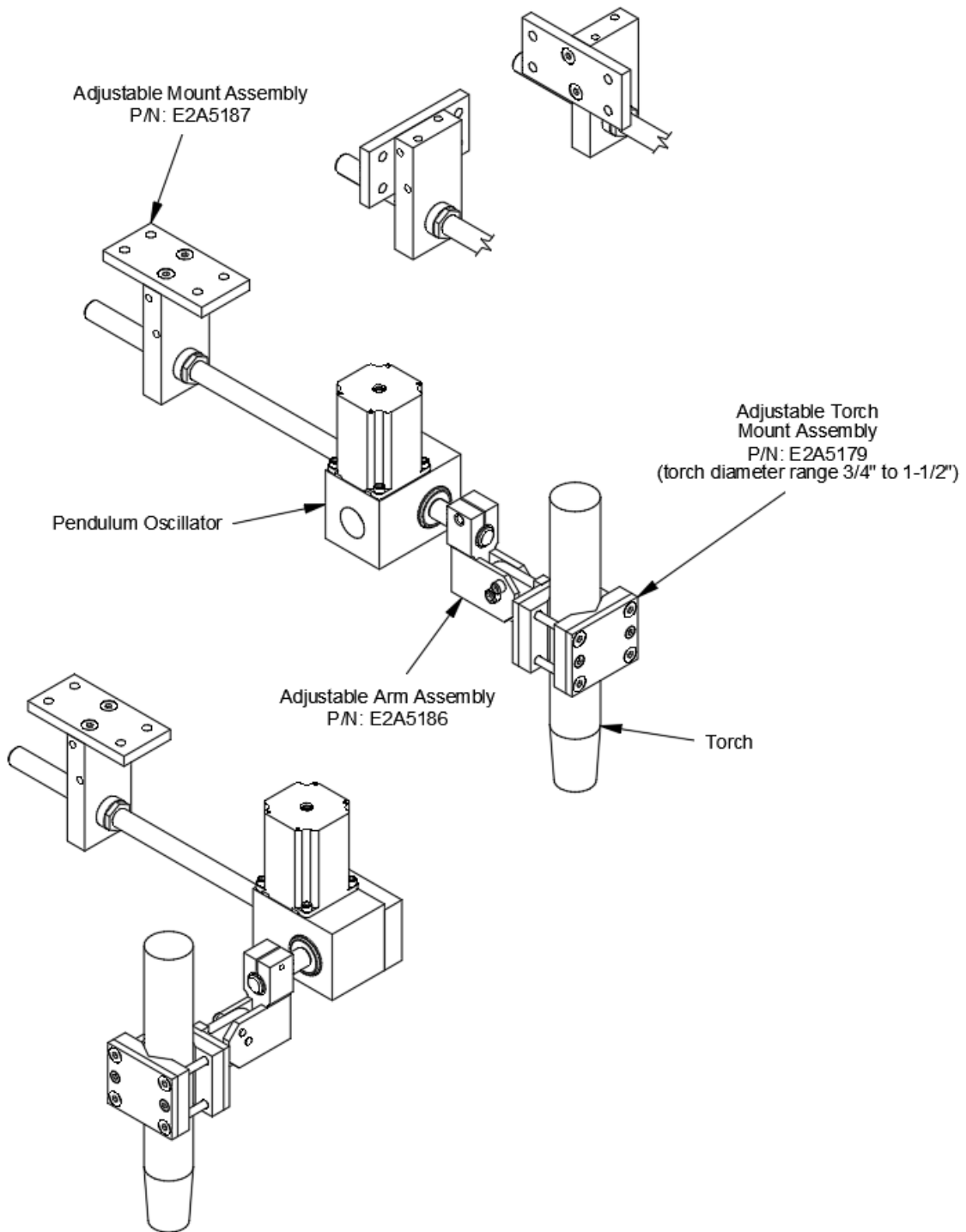

B.2 Pendulum Oscillator Adjustable Mount Assembly
P/N: E2A5187

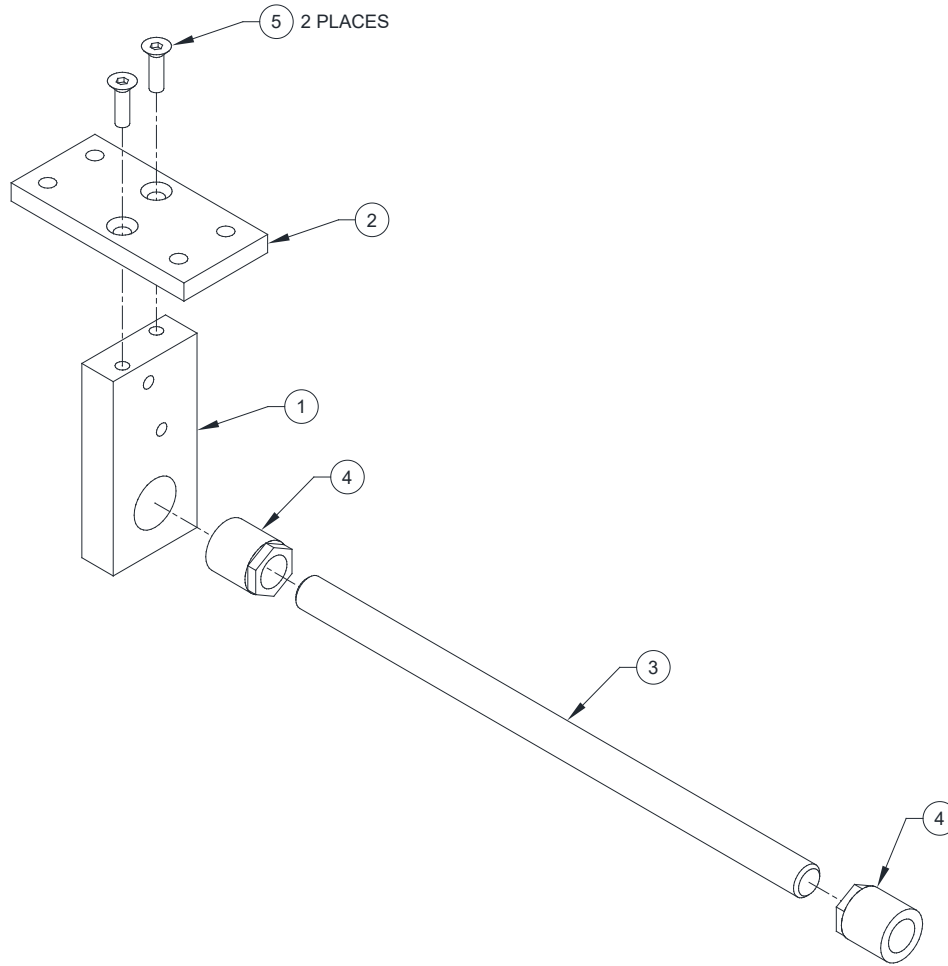

ITEM	QTY	PART NUMBER	DESCRIPTION
1	1	E2M5821	Pendulum Oscillator Shaft Mounting Plate
2	1	E2M5822	Pendulum Oscillator Base Mounting Plate
3	1	X2U5010	5/8" Dia. x 12" Long 303 SS Shaft
4	2	X6B5157	Transtorque Coupling
5	2		1/4-20 x 7/8" Long Socket Flat Head Screw

B.3 Pendulum Oscillator Adjustable Arm Assembly P/N: E2A5186

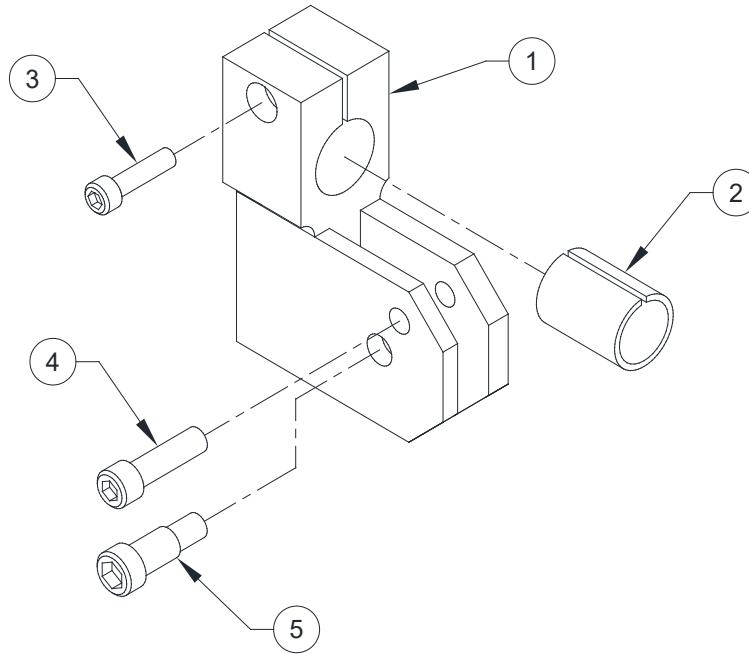

ITEM	QTY	PART NUMBER	DESCRIPTION
1	1	S2M5176	Rumble Clutch Bracket
2	1	E2M5812	Pendulum Oscillator Shaft Sleeve
3	1		#10-32 x 3/4" Long Socket Head Cap Screw
4	1		#1/4-20 x 7/8" Long Socket Head Cap Screw
5	1		5/16" Dia. x 1/2" Long x #1/4-20 Shoulder Screw

B.4 Adjustable Torch Mount Assembly P/N: E2A5185

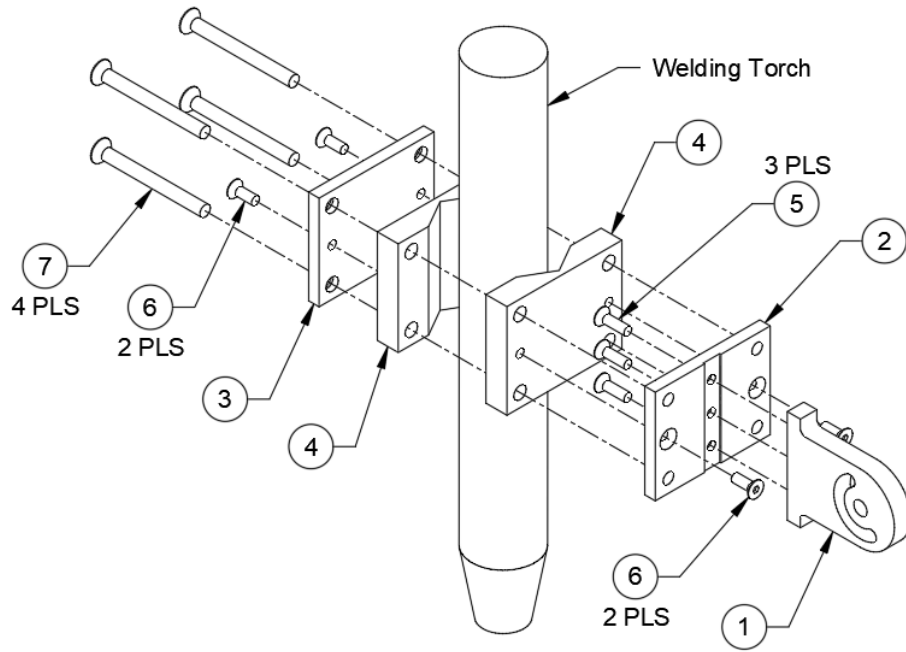

ITEM	QTY	PART NUMBER	DESCRIPTION
1	1	E2M5711	Binzel Bracket Arm
2	1	E2M5817	Torch Mount Arm Base
3	1	E2M5818	Torch Mount Clamp Base
4	2	E2M5819	Torch mount Insulator
5	3		#10-32 x 5/8" Long Socket Flat Head Screw
6	4		#10-32 x 1/2" Long Socket Flat Head Screw
7	4		#1/4-20 x 2-1/2" Long Socket Flat Head Screw

B.5 Typical Installation Layouts for Accessory Parts

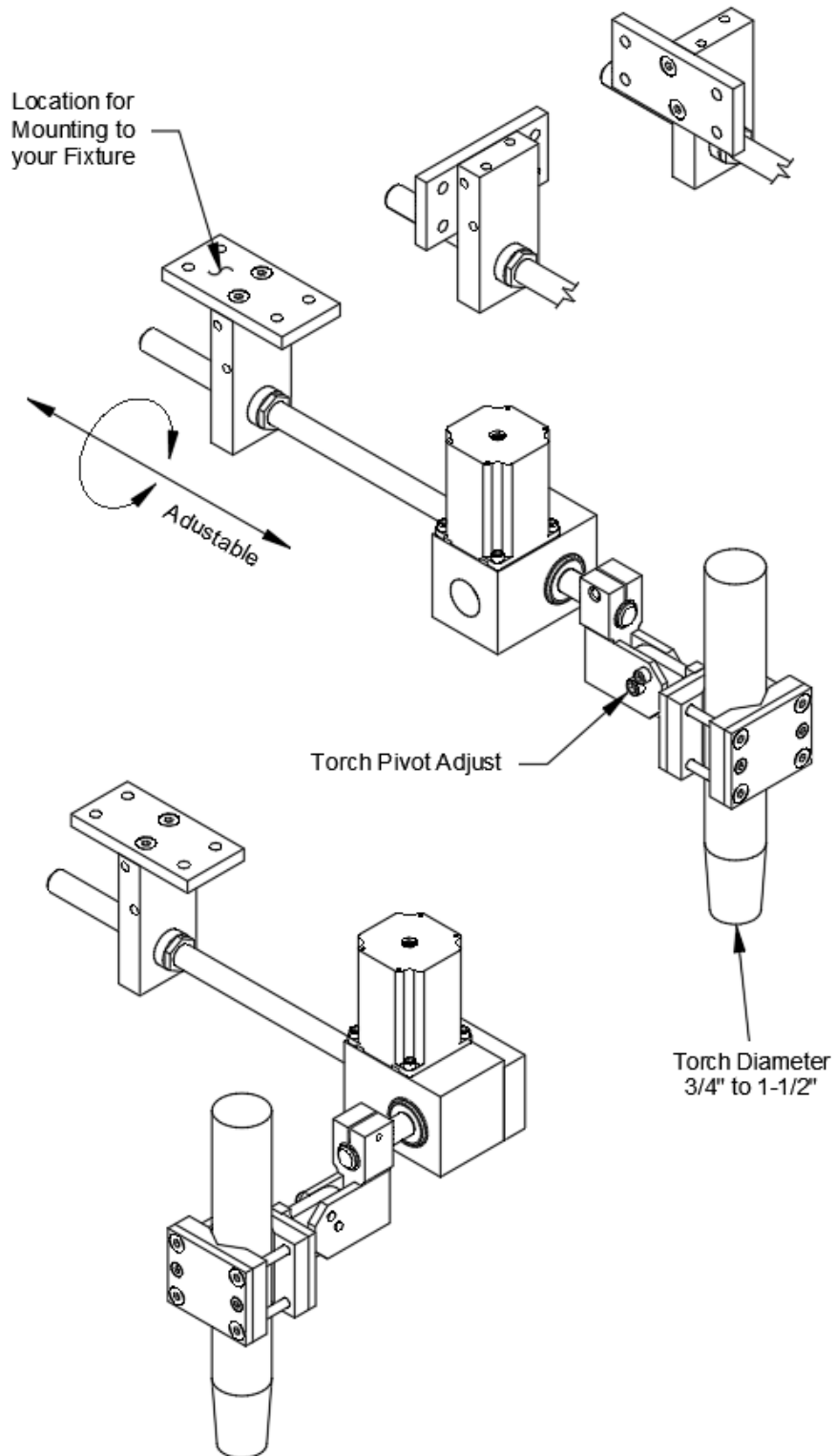

B.6 Optional Mountings for Adjustable Mount Assembly

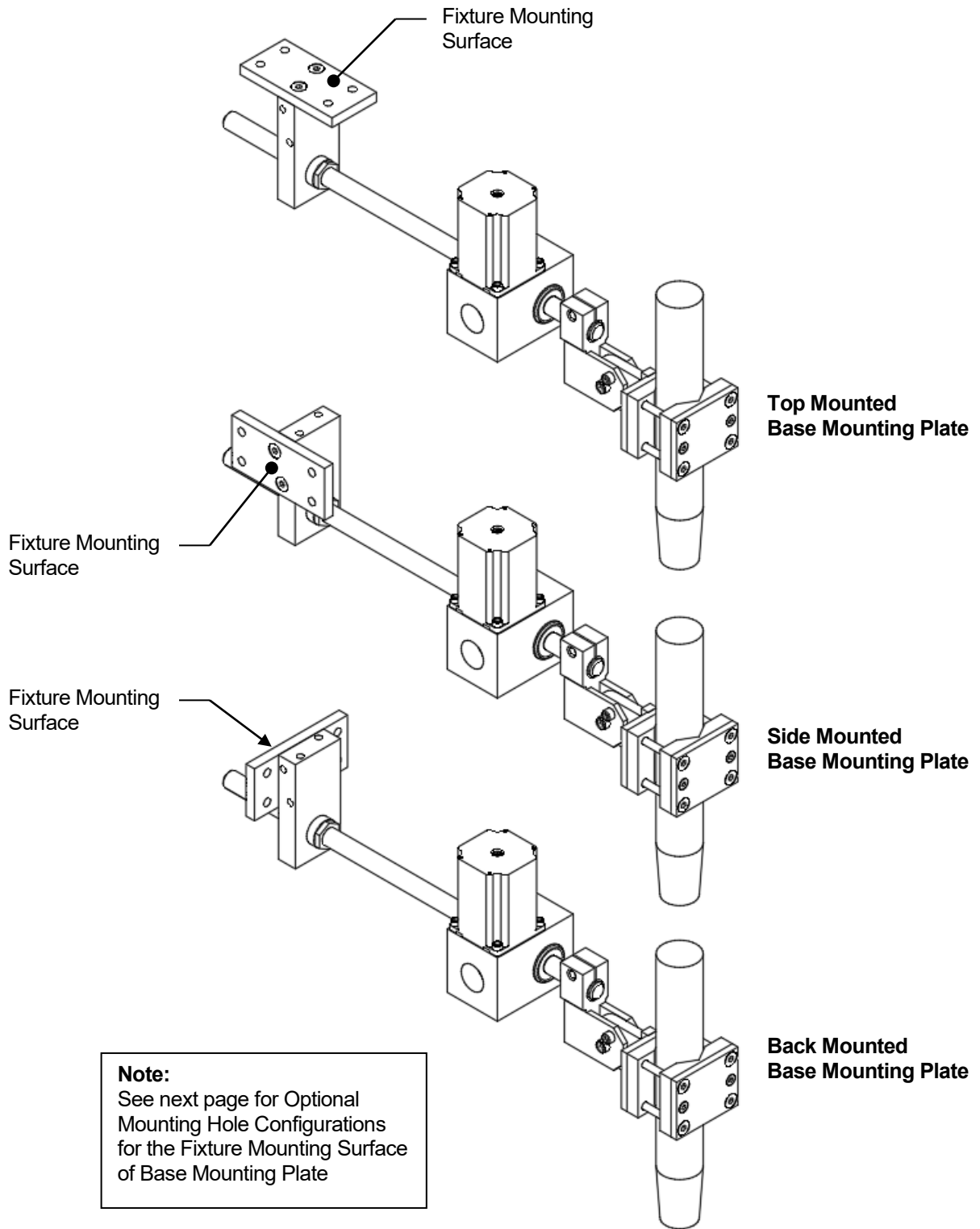

B.7 Base Mounting Plate Optional Mounting Configurations

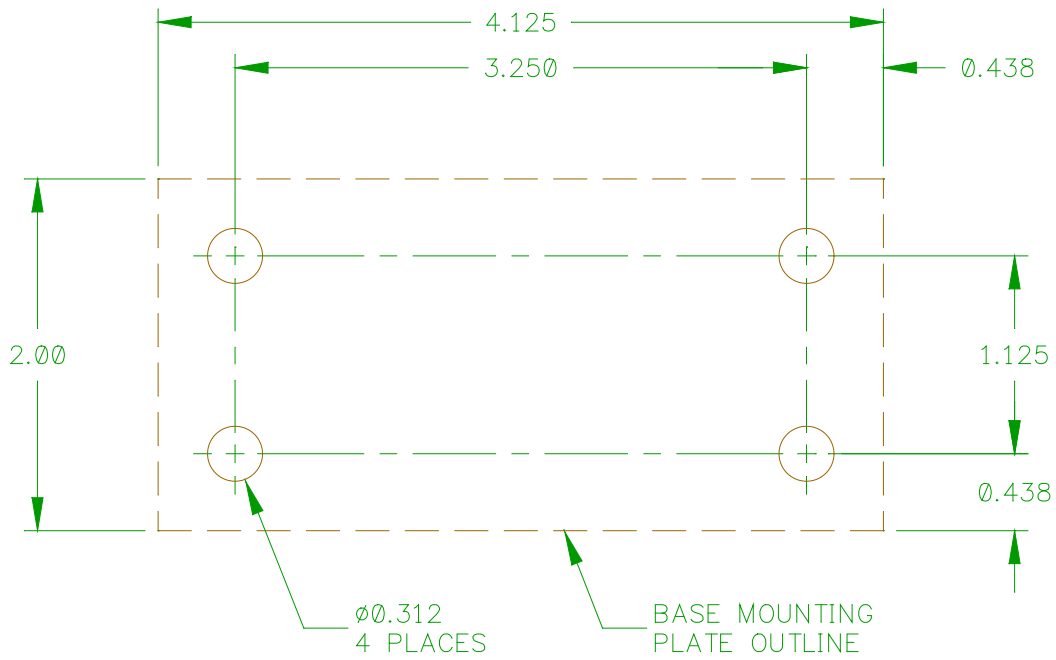

Clearance Holes Mounting

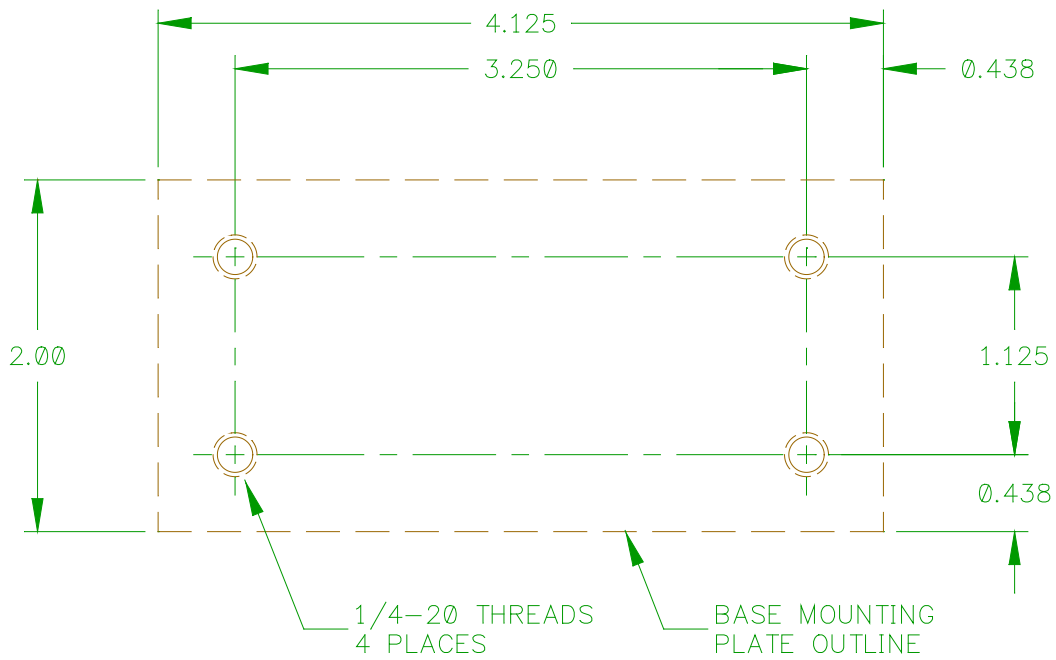

Threaded Holes Mounting

B.8 In-Line Shaft with Top Mounted Base Mounting Plate

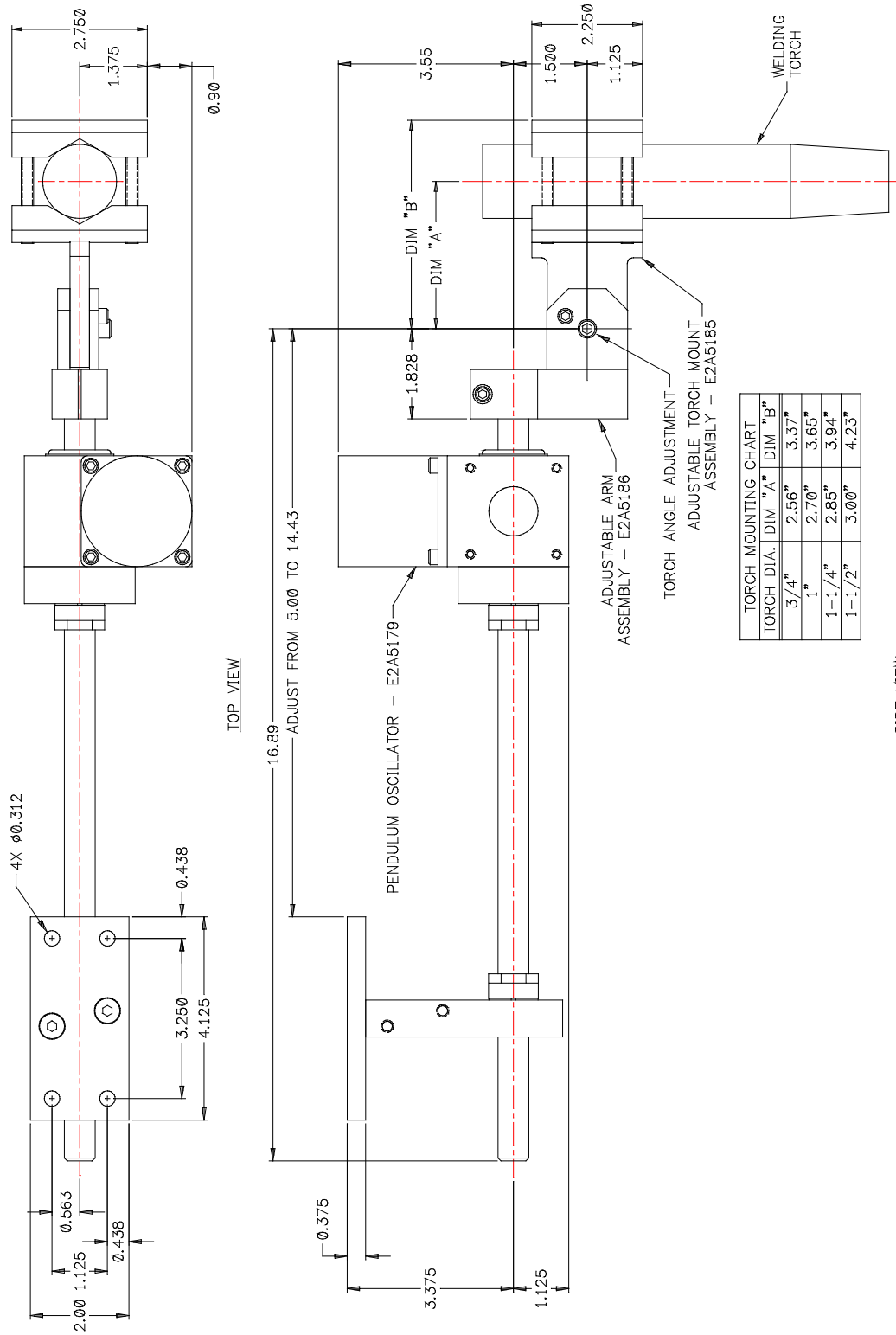

B.9 In-Line Shaft with Side Mounted Base Mounting Plate

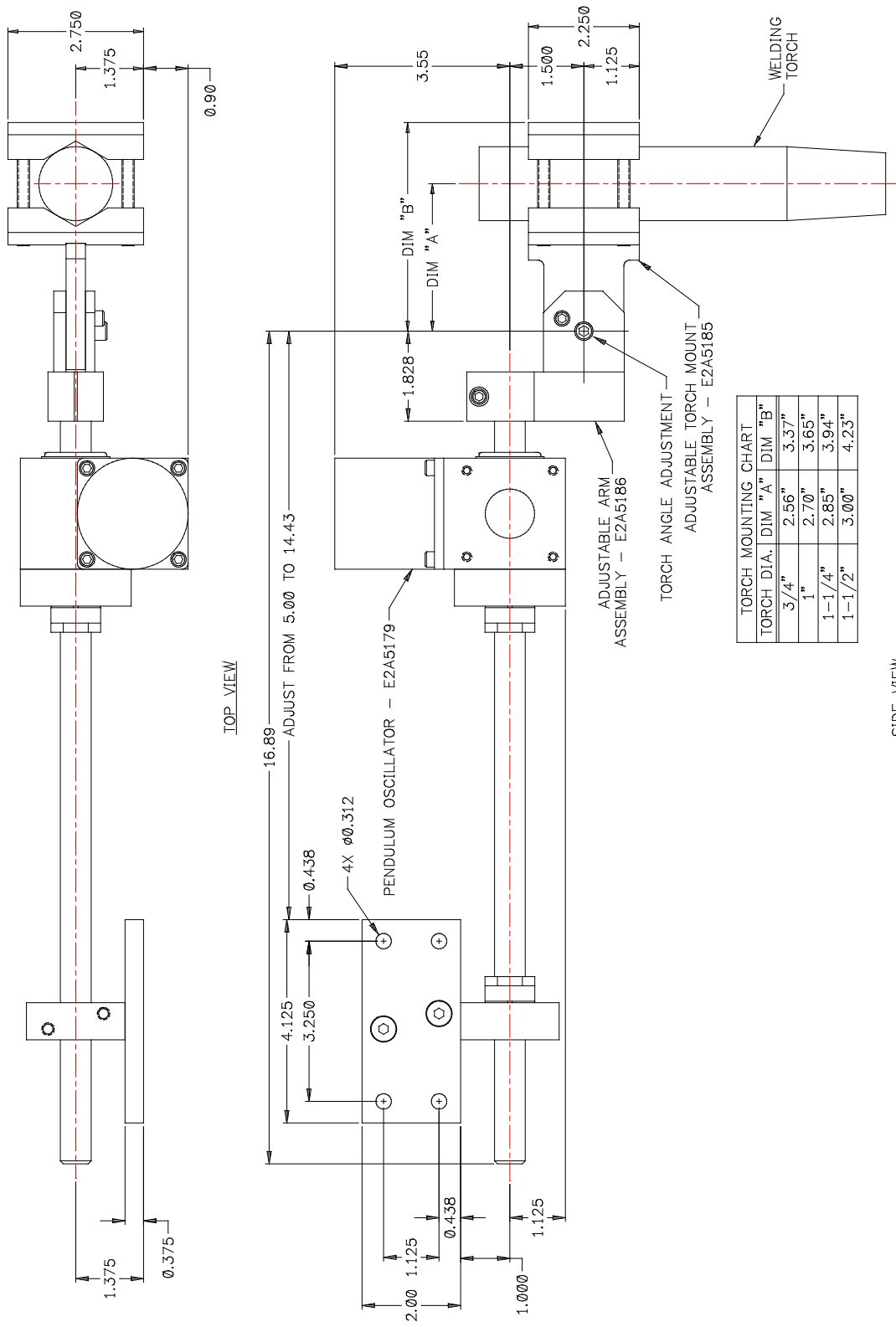

B.10 In-Line Shaft with Back Mounted Base Mounting Plate

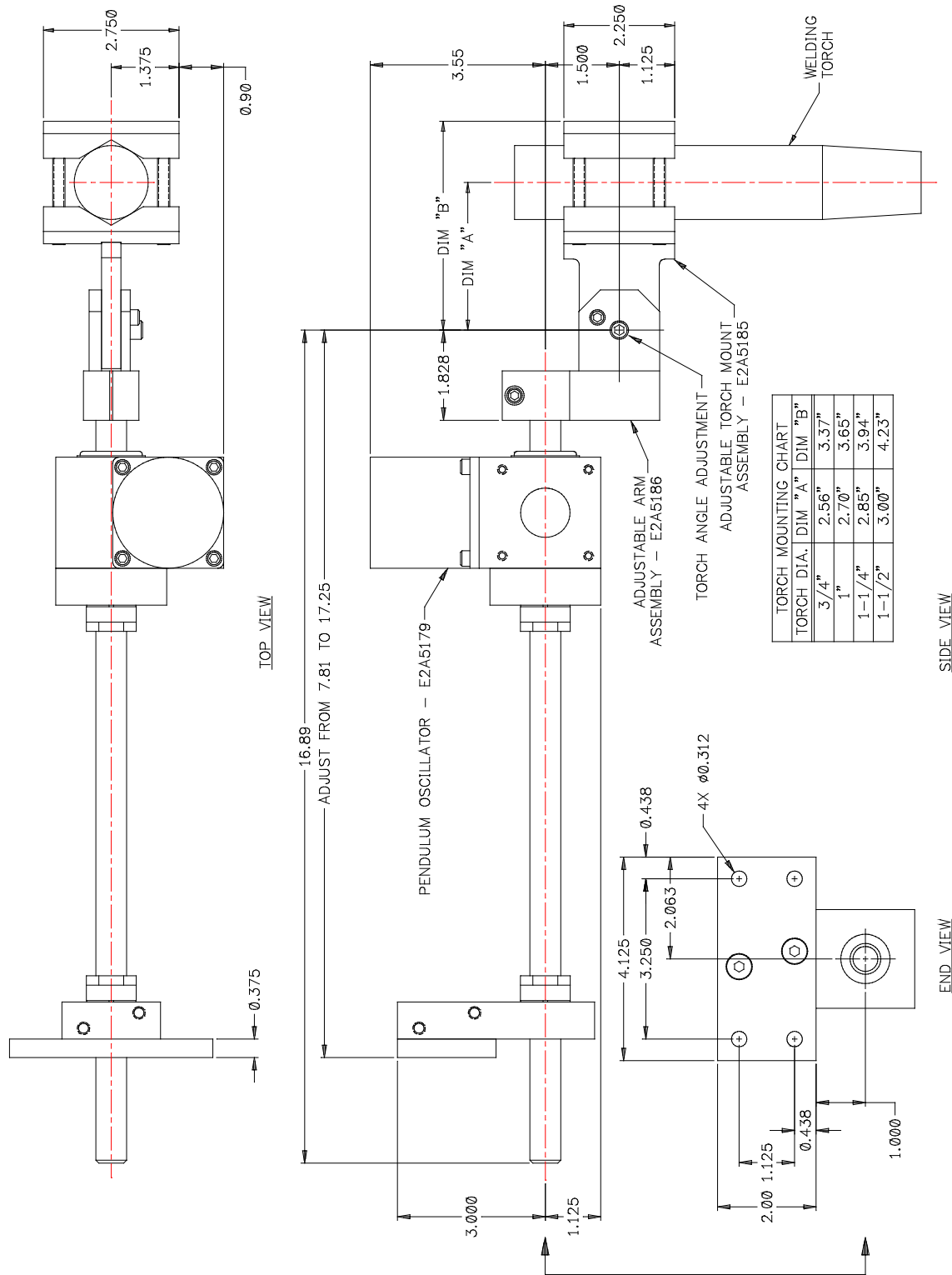

B.11 Right Angled Shaft with Top Mounted Base Mounting Plate

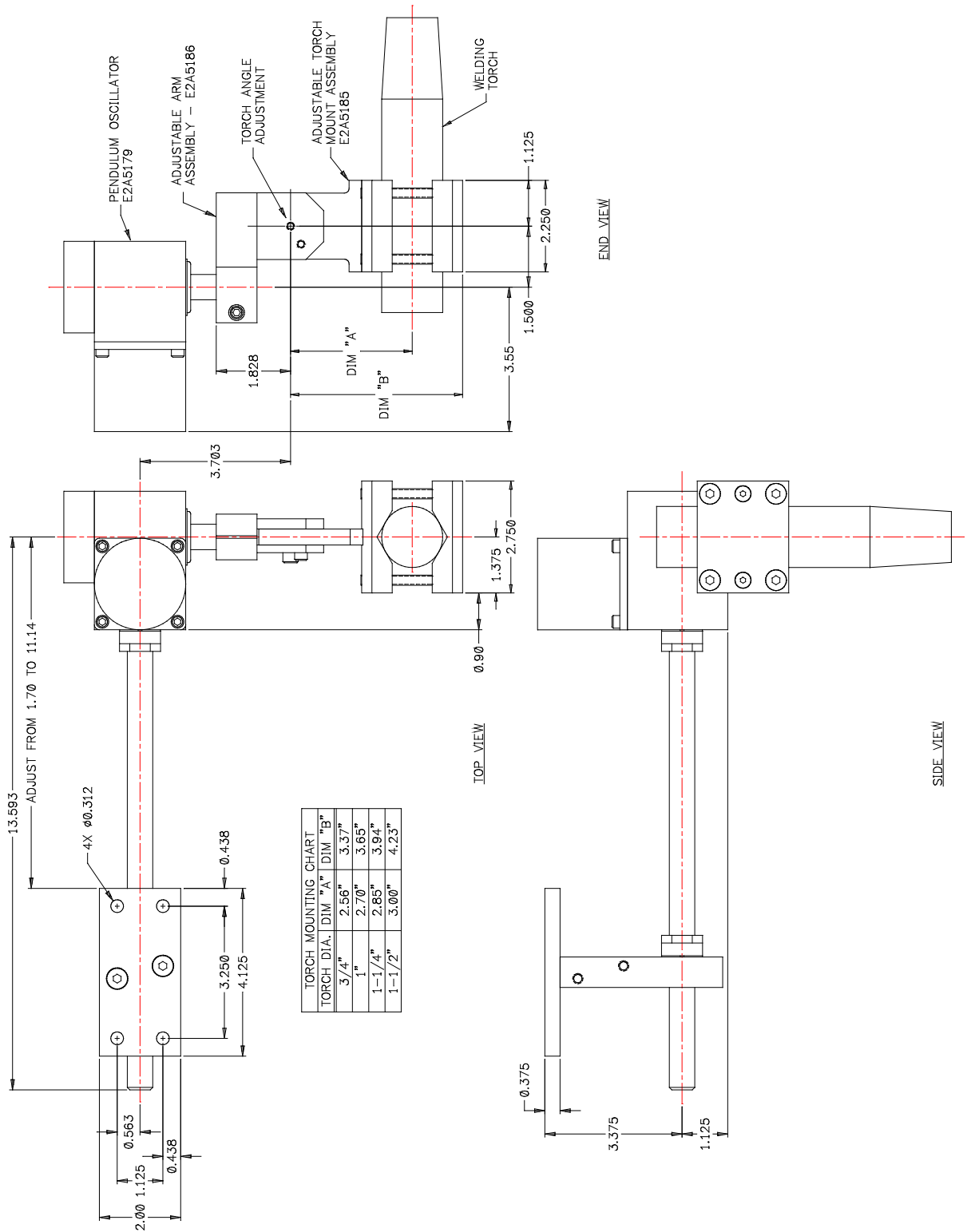

B.12 Right Angled Shaft with Side Mounted Base Mounting Plate

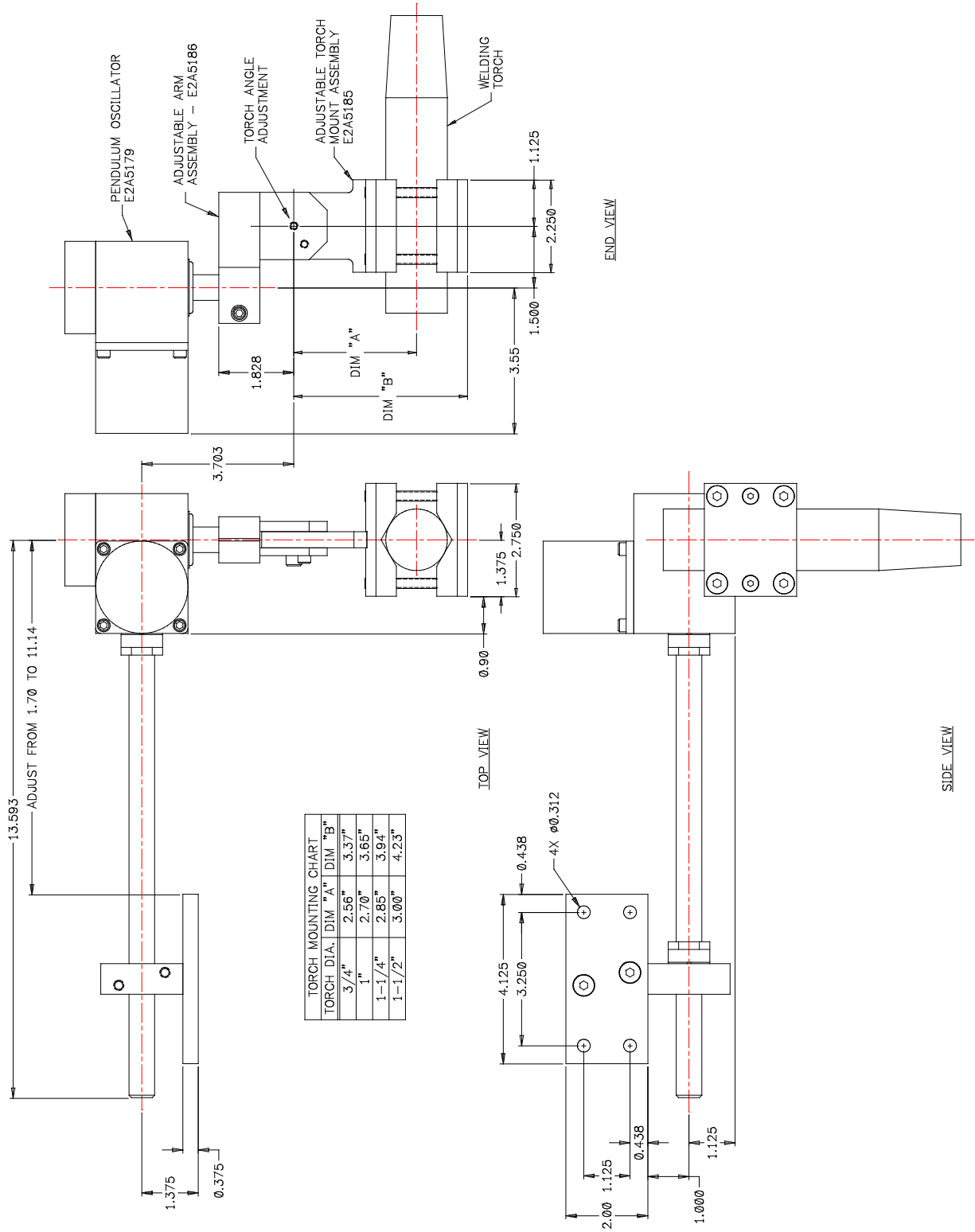

B.13 Right Angled Shaft with Rear Mounted Base Mounting Plate

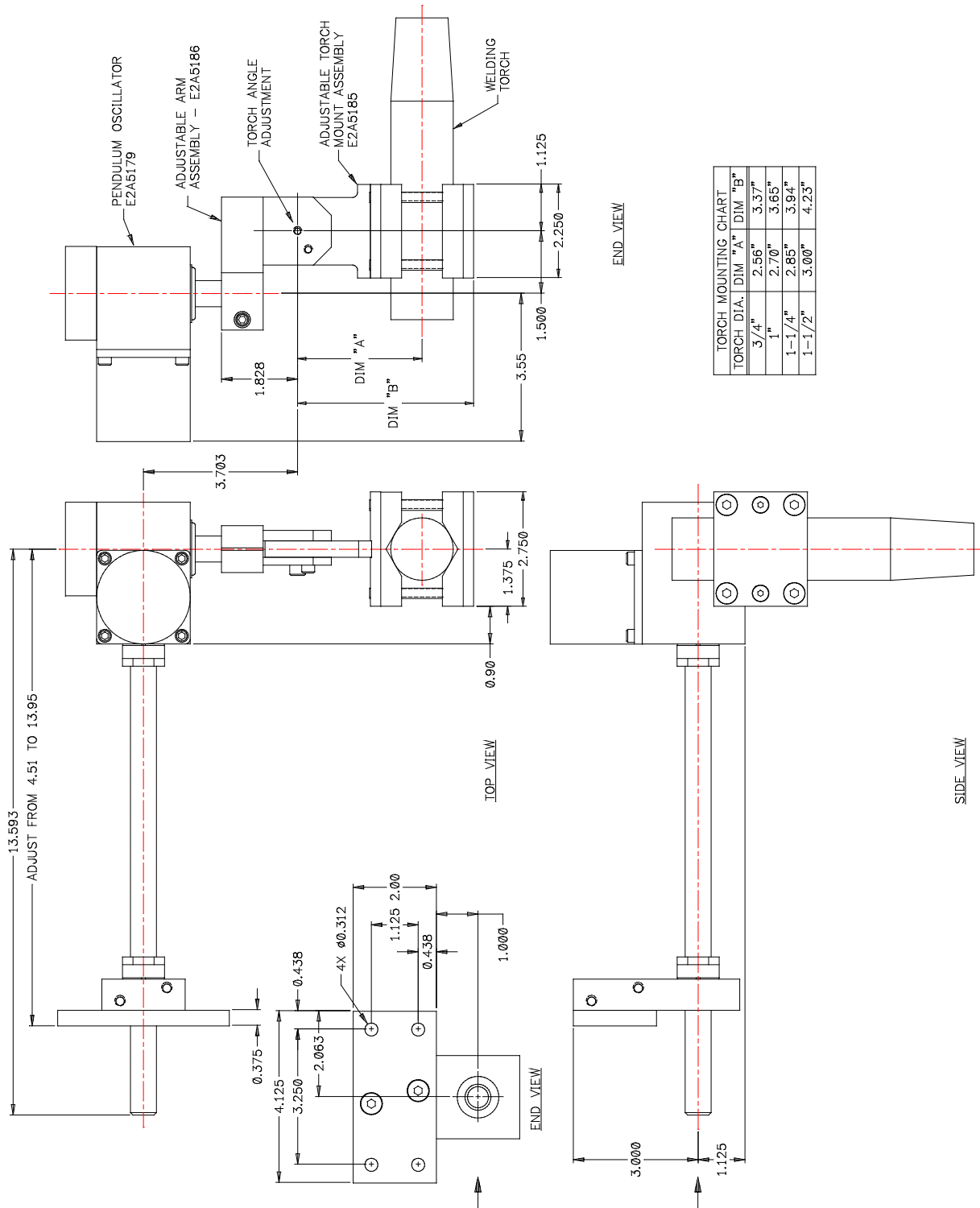

			
WARNING	<ul style="list-style-type: none"> Do not touch electrically live parts or electrode with skin or wet clothing. Insulate yourself from work and ground. 	<ul style="list-style-type: none"> Keep flammable materials away. 	<ul style="list-style-type: none"> Wear eye, ear and body protection.
Spanish AVISO DE PRECAUCION	<ul style="list-style-type: none"> No toque las partes o los electrodos bajo carga con la piel o ropa mojada. Aíslese del trabajo y de la tierra. 	<ul style="list-style-type: none"> Mantenga el material combustible fuera del área de trabajo. 	<ul style="list-style-type: none"> Protéjase los ojos, los oídos y el cuerpo.
French ATTENTION	<ul style="list-style-type: none"> Ne laissez ni la peau ni des vêtements mouillés entrer en contact avec des pièces sous tension. Isolez-vous du travail et de la terre. 	<ul style="list-style-type: none"> Gardez à l'écart de tout matériel inflammable. 	<ul style="list-style-type: none"> Protégez vos yeux, vos oreilles et votre corps.
German WARNUNG	<ul style="list-style-type: none"> Berühren Sie keine stromführenden Teile oder Elektroden mit Ihrem Körper oder feuchter Kleidung! Isolieren Sie sich von den Elektroden und dem Erdboden! 	<ul style="list-style-type: none"> Entfernen Sie brennbares Material! 	<ul style="list-style-type: none"> Tragen Sie Augen-, Ohren- und Körperschutz!
Portuguese ATENÇÃO	<ul style="list-style-type: none"> Não toque partes elétricas e electrodos com a pele ou roupa molhada. Isole-se da peça e terra. 	<ul style="list-style-type: none"> Mantenha inflamáveis bem guardados. 	<ul style="list-style-type: none"> Use proteção para a vista, ouvido e corpo.
Japanese 注意事項	<ul style="list-style-type: none"> 通電中の電気部品、又は溶材にヒフやぬれた布で触れないこと。 施工物やアースから身体が絶縁されている様にして下さい。 	<ul style="list-style-type: none"> 燃えやすいものの側での溶接作業は絶対にしてはなりません。 	<ul style="list-style-type: none"> 目、耳及び身体に保護具をして下さい。
Chinese 警告	<ul style="list-style-type: none"> 皮肤或湿衣物切勿接触带电部件及焊条。 使你自已与地面和工件绝缘。 	<ul style="list-style-type: none"> 把一切易燃物品移离工作场所。 	<ul style="list-style-type: none"> 佩戴眼、耳及身体劳动保护用具。
Korean 위험	<ul style="list-style-type: none"> 전도체나 용접봉을 젖은 헝겍 또는 피부로 절대 접촉치 마십시오. 모재와 접지를 접촉치 마십시오. 	<ul style="list-style-type: none"> 인화성 물질을 접근시키지 마십시오. 	<ul style="list-style-type: none"> 눈, 귀와 몸에 보호장구를 착용하십시오.
Arabic تحذير	<ul style="list-style-type: none"> لا تلمس الاجزاء التي يسري فيها التيار الكهربائي أو الألكترود بجسدك أو بالملابس المبللة بالماء. ضع عازلا على جسمك خلال العمل. 	<ul style="list-style-type: none"> ضع المواد القابلة للاشتعال في مكان بعيد. 	<ul style="list-style-type: none"> ضع أدوات وملابس واقية على عينيك وأذنيك وجسمك.

READ AND UNDERSTAND THE MANUFACTURER'S INSTRUCTION FOR THIS EQUIPMENT AND THE CONSUMABLES TO BE USED AND FOLLOW YOUR EMPLOYER'S SAFETY PRACTICES.

SE RECOMIENDA LEER Y ENTENDER LAS INSTRUCCIONES DEL FABRICANTE PARA EL USO DE ESTE EQUIPO Y LOS CONSUMIBLES QUE VA A UTILIZAR, SIGA LAS MEDIDAS DE SEGURIDAD DE SU SUPERVISOR.

LISEZ ET COMPRENEZ LES INSTRUCTIONS DU FABRICANT EN CE QUI REGARDE CET EQUIPMENT ET LES PRODUITS A ETRE EMPLOYES ET SUIVEZ LES PROCEDURES DE SECURITE DE VOTRE EMPLOYEUR.

LESEN SIE UND BEFOLGEN SIE DIE BETRIEBSANLEITUNG DER ANLAGE UND DEN ELEKTRODENEINSATZ DES HERSTELLERS. DIE UNFALLVERHÜTUNGSVORSCHRIFTEN DES ARBEITGEBERS SIND EBENFALLS ZU BEACHTEN.

			
<ul style="list-style-type: none"> ● Keep your head out of fumes. ● Use ventilation or exhaust to remove fumes from breathing zone. 	<ul style="list-style-type: none"> ● Turn power off before servicing. 	<ul style="list-style-type: none"> ● Do not operate with panel open or guards off. 	WARNING
<ul style="list-style-type: none"> ● Los humos fuera de la zona de respiración. ● Mantenga la cabeza fuera de los humos. Utilice ventilación o aspiración para gases. 	<ul style="list-style-type: none"> ● Desconectar el cable de alimentación de poder de la máquina antes de iniciar cualquier servicio. 	<ul style="list-style-type: none"> ● No operar con panel abierto o guardas quitadas. 	Spanish AVISO DE PRECAUCION
<ul style="list-style-type: none"> ● Gardez la tête à l'écart des fumées. ● Utilisez un ventilateur ou un aspirateur pour ôter les fumées des zones de travail. 	<ul style="list-style-type: none"> ● Débranchez le courant avant l'entretien. 	<ul style="list-style-type: none"> ● N'opérez pas avec les panneaux ouverts ou avec les dispositifs de protection enlevés. 	French ATTENTION
<ul style="list-style-type: none"> ● Vermeiden Sie das Einatmen von Schweißrauch! ● Sorgen Sie für gute Be- und Entlüftung des Arbeitsplatzes! 	<ul style="list-style-type: none"> ● Strom vor Wartungsarbeiten abschalten! (Netzstrom völlig öffnen; Maschine anhalten!) 	<ul style="list-style-type: none"> ● Anlage nie ohne Schutzgehäuse oder Innenschutzverkleidung in Betrieb setzen! 	German WARNUNG
<ul style="list-style-type: none"> ● Mantenha seu rosto da fumaça. ● Use ventilação e exaustão para remover fumo da zona respiratória. 	<ul style="list-style-type: none"> ● Não opere com as tampas removidas. ● Desligue a corrente antes de fazer serviço. ● Não toque as partes elétricas nuas. 	<ul style="list-style-type: none"> ● Mantenha-se afastado das partes moventes. ● Não opere com os painéis abertos ou guardas removidas. 	Portuguese ATENÇÃO
<ul style="list-style-type: none"> ● ヒュームから頭を離すようにして下さい。 ● 換気や排煙に十分留意して下さい。 	<ul style="list-style-type: none"> ● メンテナンス・サービスに取りかかる際には、まず電源スイッチを必ず切して下さい。 	<ul style="list-style-type: none"> ● パネルやカバーを取り外したままで機械操作をしないで下さい。 	Japanese 注意事項
<ul style="list-style-type: none"> ● 頭部遠離煙霧。 ● 在呼吸區使用通風或排風器除煙。 	<ul style="list-style-type: none"> ● 維修前切斷電源。 	<ul style="list-style-type: none"> ● 儀表板打開或沒有安全罩時不準作業。 	Chinese 警告
<ul style="list-style-type: none"> ● 얼굴로부터 용접가스를 멀리하십시오. ● 호흡지역으로부터 용접가스를 제거하기 위해 가스제거기나 통풍기를 사용하십시오. 	<ul style="list-style-type: none"> ● 보수전에 전원을 차단하십시오. 	<ul style="list-style-type: none"> ● 판넬이 열린 상태로 작동치 마십시오. 	Korean 위험
<ul style="list-style-type: none"> ● ابعد رأسك بعيداً عن الدخان. ● استعمل التهوية أو جهاز ضغط الدخان للخارج لكي تبعد الدخان عن المنطقة التي تتنفس فيها. 	<ul style="list-style-type: none"> ● أقطع التيار الكهربائي قبل القيام بأية صيانة. 	<ul style="list-style-type: none"> ● لا تشغيل هذا الجهاز اذا كانت الاغطية الحديدية الواقية ليست عليه. 	Arabic تحذير

LEIA E COMPREENDA AS INSTRUÇÕES DO FABRICANTE PARA ESTE EQUIPAMENTO E AS PARTES DE USO, E SIGA AS PRÁTICAS DE SEGURANÇA DO EMPREGADOR.

使う機械や溶材のメーカーの指示書をよく読み、まず理解して下さい。そして貴社の安全規定に従って下さい。

請詳細閱讀並理解製造廠提供的說明以及應該使用的銀焊材料，並請遵守貴方的有關勞動保護規定。

이 제품에 동봉된 작업지침서를 숙지하시고 귀사의 작업자 안전수칙을 준수하시기 바랍니다.

اقرأ بتمعن وافهم تعليمات المصنع المنتج لهذه المعدات والمواد قبل استعمالها واتبع تعليمات الوقاية لصاحب العمل.

CUSTOMER ASSISTANCE POLICY

The business of The Lincoln Electric Company is manufacturing and selling high quality welding equipment, consumables, and cutting equipment. Our challenge is to meet the needs of our customers and to exceed their expectations. On occasion, purchasers may ask Lincoln Electric for advice or information about their use of our products. We respond to our customers based on the best information in our possession at that time. Lincoln Electric is not in a position to warrant or guarantee such advice, and assumes no liability, with respect to such information or advice. We expressly disclaim any warranty of any kind, including any warranty of fitness for any customer's particular purpose, with respect to such information or advice. As a matter of practical consideration, we also cannot assume any responsibility for updating or correcting any such information or advice once it has been given, nor does the provision of information or advice create, expand or alter any warranty with respect to the sale of our products.

Lincoln Electric is a responsive manufacturer, but the selection and use of specific products sold by Lincoln Electric is solely within the control of, and remains the sole responsibility of the customer. Many variables beyond the control of Lincoln Electric affect the results obtained in applying these types of fabrication methods and service requirements.

Subject to Change – This information is accurate to the best of our knowledge at the time of printing. Please refer to www.lincolnelectric.com for any updated information.



THE LINCOLN ELECTRIC COMPANY

22801 St. Clair Avenue • Cleveland, OH • 44117-1199 • U.S.A.
Phone: +1.216.481.8100 • www.lincolnelectric.com